

FABRAL[®]

A FLACK GLOBAL METALS COMPANY

HANDBOOK OF CONSTRUCTION DETAILS

ARCHITECTURAL PRODUCTS FOR THE BUILDING INDUSTRY

1/2" SSR, Decor-Flush, Prestige, Twin Fold, GrandCurve,
High Seam, Posi-Lock Soffit, Slim Seam[®], Snap-on-Batten,
Snap-On-Seam, Stand'N Seam[®], Thin Seam, T-Rib

FOR

- X METAL ROOFING SYSTEMS
- X FASCIA AND MANSARDS
- X SOFFITS

Manufacturing Locations

Lancaster, PA: (717) 638-2809
Jackson, GA: (770) 230-8093
Ft. Worth, TX: (817) 286-5100
Gridley IL: (309) 280-6205
St. Joseph, MN: (816) 205-8111
Marshfield, WI: (715) 800-6006
Salt Lake City, UT: (385) 243-6333
Spokane, WA: (509) 204-8013

TABLE OF CONTENTS

Introduction	3
General Notes	4
Hem Lengths	5
Maintenance Instructions	6
Panel Profiles	7
UL Uplift Ratings Summary	8
Panel Attachments	9
Ridge/Hip Details	10
Peak Details	14
End Wall Details	16
Pitch Break Details	18
Gable Details	22
Sidewall Details	25
Eave Details	27
Gutter Expansion Joint	32
Valley Details	33
Roof/Fascia Transitions	35
Fascia Details	38
Pipe Boot Penetration	41
Curb Penetration	42
Construction Joint	43
Soffit Details	45
Dormer Details	46

INTRODUCTION

The details contained in the following pages are merely suggestions/guidelines as to how Fabral=s materials can be installed. We believe all information presented is accurate, but it is not intended to cover all instances, building requirements, designs, or codes. The details may require adaptations, changes, or revisions for each project since conditions will vary from one project to another and may be unique for each application.

The details shown are proven methods of construction. However, it must be noted that weathertightness is the function of the installer. The installer can virtually assure weathertightness through the use of these details, good materials and workmanship, the use of the right type(s) of sealant(s), and sealing and caulking all joints adequately.

It is the responsibility of the designer, roofing contractor and installer to ensure that the following details are adapted to meet particular building requirements and to assure adequate weathertightness. Fabral shall be held harmless from any and all claims arising from a lack of weathertightness as a result of following these suggested typical detailed drawings. The designer and installer must be aware of and allow for expansion/contraction of roof panels when designing and/or installing panels and flashings.

Likewise, ensuring adequacy of anchoring framing materials to walls, structures, subgirts and cees/zees, shall be determined by the designer and installer and Fabral shall be held harmless against all claims resulting from any inadequacy.

The installer shall be familiar with all erection instructions before starting work. Before beginning erection of the panels, the installer shall examine the substrate to ensure that all supporting members are straight, level, plumb, and true in accordance with minimum tolerances. Report any variations and potential problems to the general contractor or architect. Do not start work until unsatisfactory conditions have been corrected.

The roofing/fascia/soffit system shall be installed plumb, straight, and true to adjacent work. Horizontal panel lap joints are not acceptable. EPDM closures and metal top closures shall be caulked around their entire perimeter. Roof clips shall allow for thermal movement and shall be installed at each panel joint. Longitudinal spacing of roof clips shall be as specified for design loads. No

perforations shall be made in roofing/fascia/soffit by fasteners, except as shown on drawings. To control thermal expansion in one direction, the panel must be fixed either at the top of the panel or at the bottom of the panel. An eave bend down detail will fix the panel at the eave. Therefore, the ridge should be allowed to slide for such a case. Never fix both ends of the panel. Always use a sliding ridge with a fixed eave and always use a fixed ridge with a sliding eave.

All flashings, closures, and accessories shall be provided by Fabral as indicated, and as necessary to provide a weathertight installation. Installation procedures which are not indicated shall be in accordance with the panel manufacturer's printed instructions and details or the approved shop drawings. Flashings and trim shall be installed true and in proper alignment with any exposed fasteners equally spaced for the best appearance.

Sealant for joints and flashing endlaps shall be non-drying, non-toxic, non-shrinking and shall have a serviceable temperature of -50 to 212°F. Sealant shall be field-applied on dry, clean surfaces. To ensure weathertightness, the sealant shall be installed where indicated without skips or voids. Sealants shall be furnished by others.

The installer may utilize details provided and procedures recommended for installation of materials. Some field cutting and fitting of panels and flashings is expected of the installer and minor field corrections of materials is a part of normal erection work. Workmanship shall be the best industry standards and installation shall be performed by experienced metal craftsmen. Oil canning in the flat area of the pans is common to the industry and shall not be cause for product refusal.

SMACNA (Sheet Metal and Air Conditioning Contractors National Association) architectural sheet metal manual specifications shall govern for material and workmanship not shown.

GENERAL NOTES

1. Stand'N Seam, Slim Seam, and GrandCurve (narrow batten) panels require the use of clip screws with low profile heads. Purchase these screws from Fabral only.
2. Amp Lok, Stand'N Seam, Slim Seam, T-Rib, and Thin Seam panels may be used over purlins. All other roofing panels require a installation over a solid substrate.
3. Posi-Lock Soffit panels are to be used as soffit panels only. Decor-Flush panels should not be used as roofing panels.
4. Before releasing materials for fabrication, it is recommended that panel lengths, quantities, profiles and dimensions of flashings or flat sheet quantities be verified through field measurements. Fabral shall not be liable for any back charges for errors and/or omissions after approved shop drawings are released for fabrication by the customer.
5. Before beginning installation, inspect/examine the surfaces to receive the panels. Do not begin installation of metal panels if the substrate (trusses, joists, subgirts/furring strips, plywood deck, steel deck, insulation, etc.) is uneven, not uniform or symmetrical, out of plumb, or in otherwise unsatisfactory condition, since such conditions can cause oil canning of panels.
6. Report unsatisfactory conditions to the general contractor. Beginning installation of panels shall mean acceptance of existing conditions with the substrate.
7. Due to inconsistencies such as those noted above, the industry has accepted a certain amount of waviness or oil canning evident in the flat area of the rib/seam panels. This is more evident on longer length panels, particularly when sunlight hits them at certain times of the day. This shall not be construed as a product defect and shall not be cause for product refusal.
8. Panel crates must be lifted at bundle block locations. Do not lift material with ropes or wires. Do not lift panels greater than 25'-0" long without a spreader bar. Do not lift panels from ends while flat. Do lift panels on edge.
9. Installation of metal panels must be started so that the sheets are held true, plumb, and straight. Note that all panel width dimensions are nominal. During panel installation, it is recommended that periodic checks/measurements be taken to ensure that the panels are not gaining or losing width.

10. During panel installation, do not use undue pressure to interlock panel. Do not force or push panels together. To reduce wavy, oil canning panel appearance and to increase the aesthetics of an installation, a camber or outward bowing may be forced into the flat area of the panel as the fastener and/or clip is installed. However, care must be taken to prevent "fish mouthing" at panel ends.
11. Fabral is not responsible for the adequacy of attachment of its framing members to other surface conditions. All fasteners for such attachments shall be the responsibility of others and Fabral shall be held harmless on such connections.
12. Ensure that acid residue from cleanup of stucco in the adjacent panel areas is not washed down directly over the panels. This could mar the finish/coating.
13. Avoid damage or scratching of the exterior surface caused by walking, use of improper tools, improper storage, etc.
14. Flashings must lap a minimum of 6". Treat flashing endlaps similar to a panel detail utilizing two rows of sealant tape with stitch screws 4" o.c. maximum. Lap flashings shingle style to allow for water flow.
15. Quality long-life butyl sealants work best as a gasket sandwiched between two pieces of metal. Always use tape sealant or butyl caulk between roof components where there will be movement. These types of sealants do not cure. Therefore, they permit movement while still providing a seal. Non-acetic acid cured silicone or one-part polyurethane sealants are recommended when voids must be filled and there is no movement.
16. If the material is not to be used immediately, it should be stored in a dry place where exposure to moisture is minimal. Moisture (from rain, snow, condensation, etc.) trapped between pieces of material may cause water stains or white rust which can affect the service life of the material and will detract from its appearance. To avoid staining or white rust, store the material in a well-ventilated dry area. Break the steel strapping bands used for shipment and store with the stacks of material in an inclined position. If outdoor storage cannot be avoided, protect the material with a canvas or waterproof paper cover. Do not use plastic which can cause sweating or condensation. Keep the material off the ground in an inclined position with an insulator such as wood. It is the responsibility of the contractor to

insure that all materials are properly stored at the jobsite.

HEM LENGTHS

A standing seam roof panel experiences changes in panel length with changes in panel temperature. One end of the panel is fixed to the substrate while the other end is free to move. The panel end that is free to move requires a hem that engages a cleat that is fixed to the substrate. The hem and cleat permit the panel end to move along the plane of the roof while holding the panel flat. Because there is movement between the hem and cleat, the sealant used in the hem and cleat must be one that doesn't cure. Suitable sealants include butyl caulk and sealant tape.

The thermal movement also requires proper design of the hem and cleat. The length of the hem needed at the end of a panel will vary with the temperature range that the panel experiences and the length of the panel. Unless a more exact analysis of the temperature during installation compared to the anticipated temperature range is conducted, use the following equation and the Thermal Movement Table. When installing panels, be sure to leave room at the end of the panel that will experience movement for the "starting gap" which is the required air space (X) between the panel and cleat. Be sure that the hem is not tight against the cleat (unless the panels are being installed in the coldest temperatures the panel will experience). Also be sure that the lower edge of the hem will not contact any flashings when the panels contract.

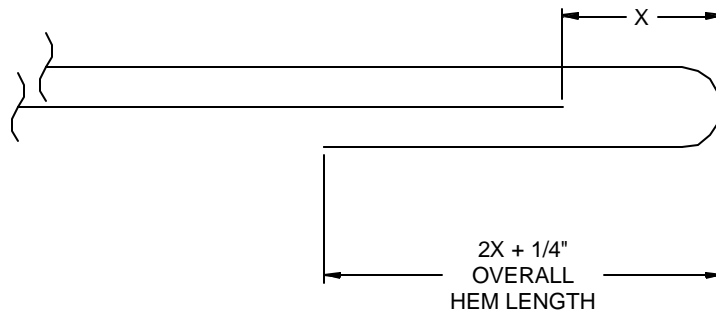

THERMAL MOVEMENT TABLE

PANEL AND SUBSTRATE MATERIALS	PANEL LENGTH (FT.)		
	10'	50'	100'
steel on rigid insulation	3/32"	13/32"	25/32"
steel on wood	1/16"	3/8"	5/8"
steel on steel	1/16"	3/8"	13/32"
steel on concrete	1/16"	3/8"	15/32"
aluminum on rigid insulation	5/32"	25/32"	1 9/16"
aluminum on wood	5/32"	11/16"	1 3/8"
aluminum on steel	1/8"	19/32"	1 5/32"
aluminum on concrete	1/8"	5/8"	1 7/32"

This table assumes a temperature change of 100°F for the panel and 50°F for the substrate.

MAINTENANCE INSTRUCTIONS FOR FABRAL PANELS

I. MAINTENANCE BY INSTALLER BEFORE LEAVING JOBSITE

1. **REMOVE METAL FILINGS** from panels and flashings at the end of each day. Filings from drilling, grinding and cutting can rust overnight. At end of the project, make a final check for any filings. If rust spots have already appeared they can be removed with a non-abrasive cleaner such as Soft Scrub. Do not use abrasive cleaners.
2. **TOUCH-UP PAINT** should be used on scratches, but it should be used sparingly and applied with a small artist's brush. If scratches penetrate the zinc coating on galvanized material, a zinc rich primer should be used before the touch-up paint is applied.
3. **CLEAN OR POWER WASH** panels as necessary after completion of project. This includes removing excess unsightly caulking. Caulking can be removed with mineral spirits. Rinse residue with clean water.
4. **REMOVE DEBRIS AND CRATING MATERIAL** from the site.

II. ROUTINE MAINTENANCE FOR METAL WALLS AND ROOFS OVER LIFE OF BUILDING

1. **FILE ALL JOB RECORDS**, including project plans, specifications, shop drawings, warranties (if any), etc., for future reference.
2. **SET UP MAINTENANCE INSPECTION SCHEDULE**. Metal wall panels normally require little maintenance, but to assure optimum serviceability, a routine inspection should be conducted at intervals no greater than once a year.

NOTE: STEEP METAL ROOFS CAN BE SLIPPERY. A QUALIFIED METAL ROOFING CONTRACTOR MAY BE REQUIRED FOR ROOF INSPECTIONS.

3. **KEEP GUTTERS AND DOWNSPOUTS CLEAR** of debris that can impede water drainage.
4. **REMOVE IMMEDIATELY ANY VEGETATION OR DEBRIS** that may contact metal panels. This includes tree branches, leaves, weeds, grass, etc.
5. **CLEAN METAL PANELS** as necessary with a 5% solution, in water, of commonly used commercial and industrial detergent. Use a cloth, soft bristle brush, or pressure washer. Rinse completely with water. When surfaces are dulled by heavy deposits of dirt or other contaminants, a heavy-duty dry powdered laundry detergent (such as Tide) mixed a cup with water may be used, followed by a water rinse. Mildew may be removed by a solution of a cup of dry powdered laundry detergent (such as Tide), a cup tri-sodium phosphate (such as Soilax), 1 quart sodium hypochlorite 5% solution (bleach), mixed with 3 quarts of water. (Note: do not use bleach on Galvalume.) Tar, grease or oil may be removed by using denatured alcohol, isopropyl alcohol or mineral spirits followed by a water rinse. Proceed with caution as aggressive cleaning with the above-described procedures may damage the coating and thus void the warranty.
6. **REPAIR DAMAGE** that may have occurred to panels with caulking, touch-up paint, etc.
7. **CORRECT ANY SIGNS OF CORROSION OR DETERIORATION** as necessary.

III. ADDITIONAL ROUTINE MAINTENANCE FOR METAL ROOFS

1. **ELIMINATE ANY CONDITIONS THAT ARE CAUSING WATER TO POND AND ACCUMULATE** on roof panels.
2. **RESEAL CURBS, GUTTERS, FLASHINGS, CLOSURES, PENETRATIONS, ETC.** as necessary to maintain the weathertightness of the system. Typically, a non-acid cured silicone caulk or a one part polyurethane sealant (such as Sikaflex 201) is best for such repairs. The owner may wish to hire a metal roofing contractor for these repairs.
3. **SALT DEPOSITS SHOULD BE REMOVED** by a fresh water rinse in salt spray areas.

PANEL PROFILES

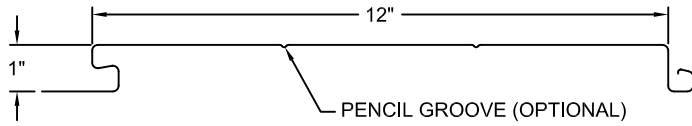

DECOR-FLUSH

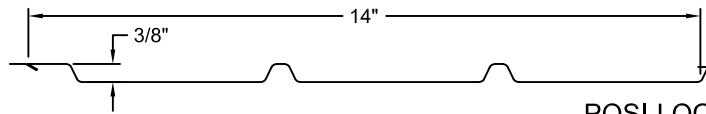
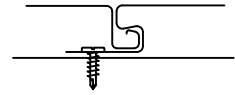

POSI-LOCK

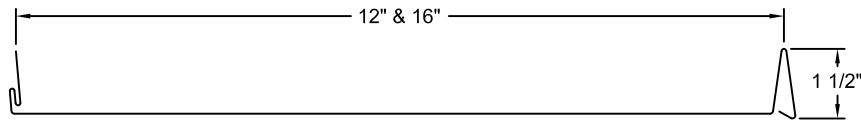

SLIM SEAM

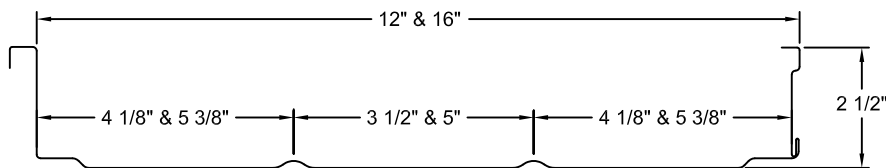
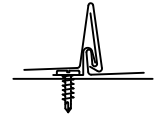

STAND'N SEAM

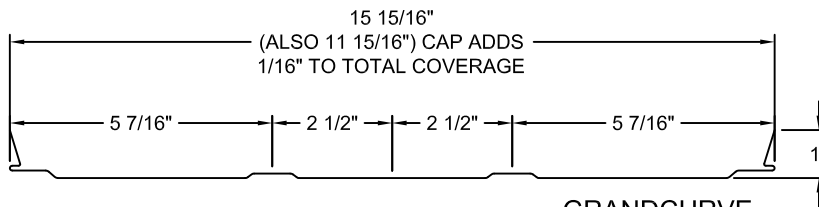
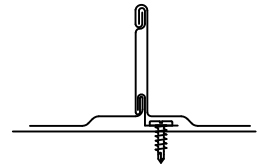

GRANDCURVE
(NARROW BATTEN)

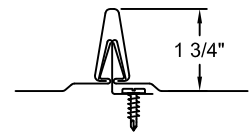

NOTE: THE 11 15/16" PAN HAS ONE CENTERED STIFFENER BEAD ONLY.

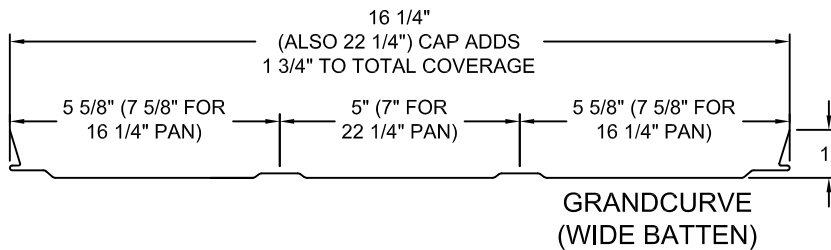

GRANDCURVE
(WIDE BATTEN)

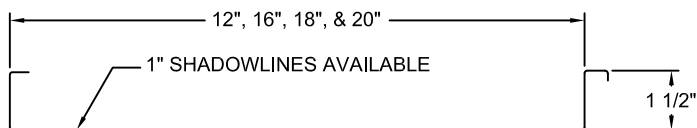
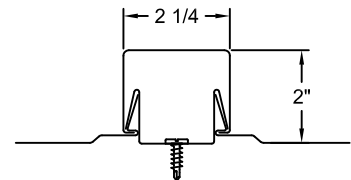

TWIN FOLD

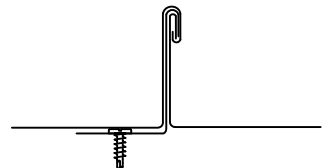

PANEL PROFILES

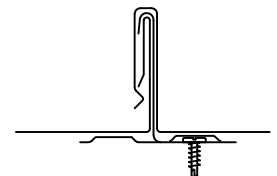
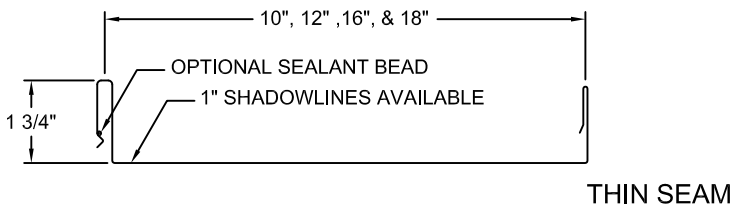
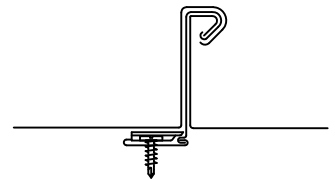
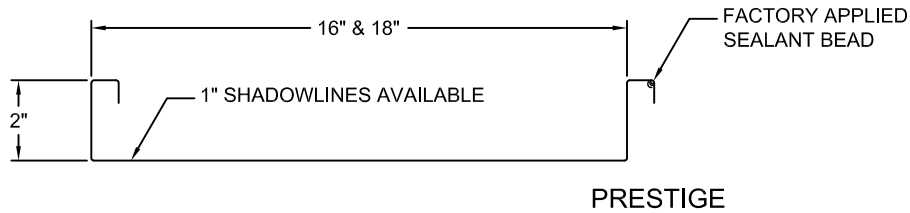
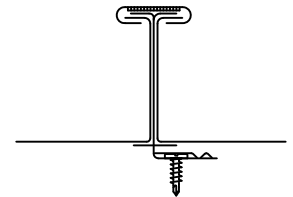
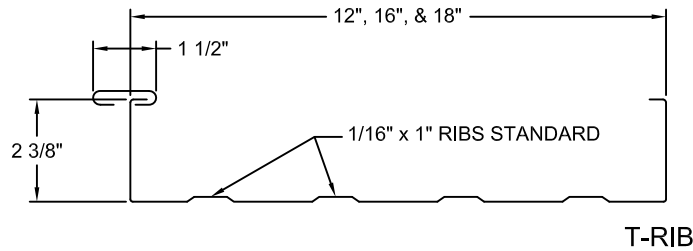
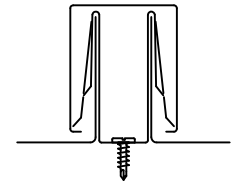
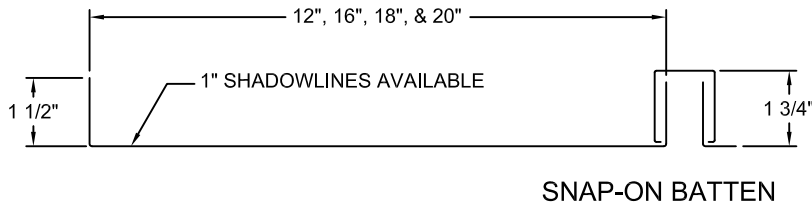
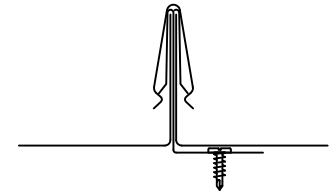
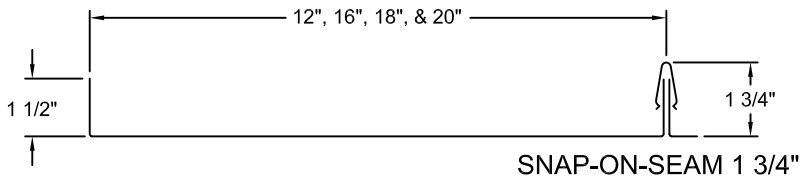
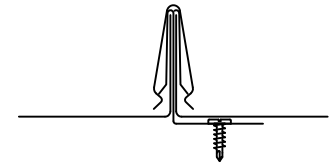
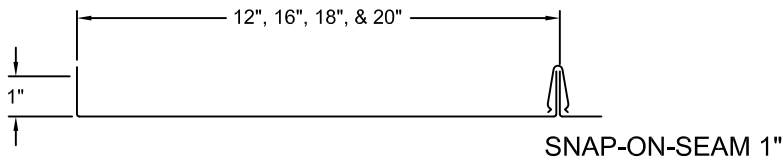
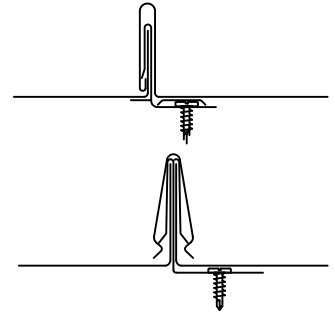
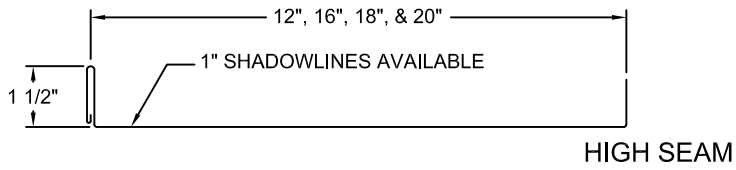

PANEL ATTACHMENTS

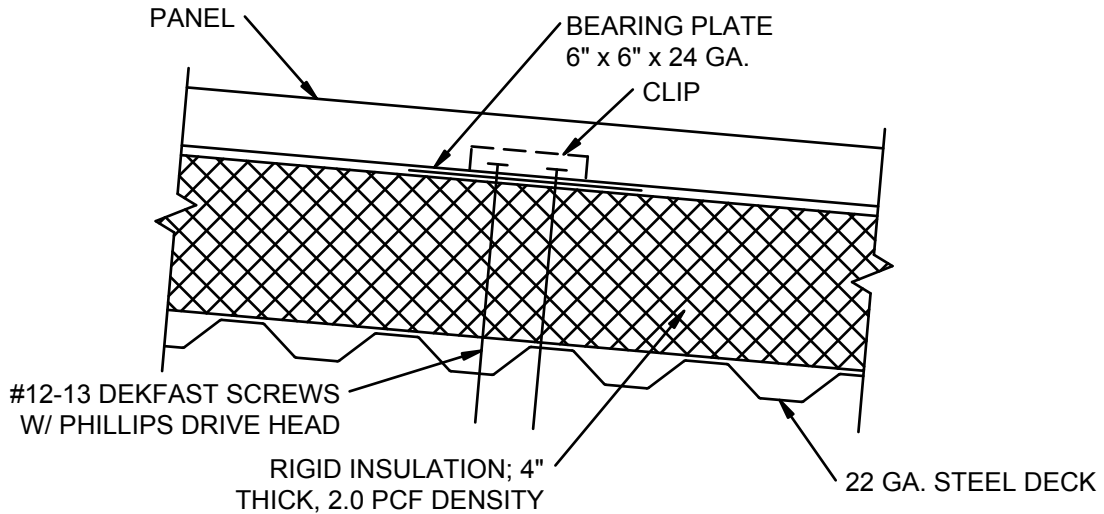

RIGID INSULATION OVER METAL DECK

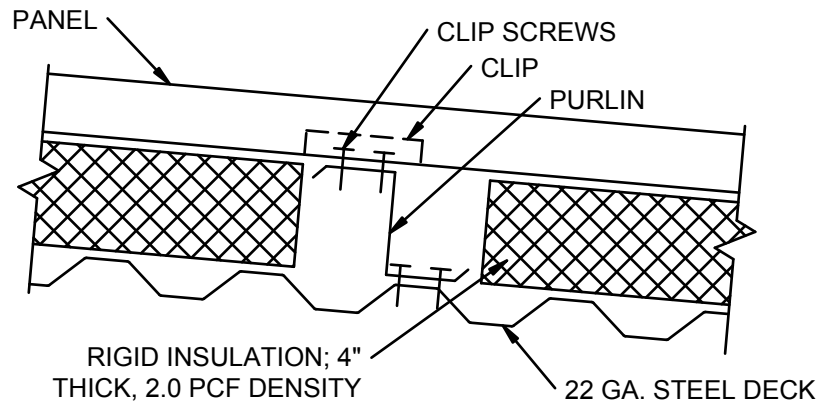

RIGID INSULATION OVER METAL DECK WITH PURLINS

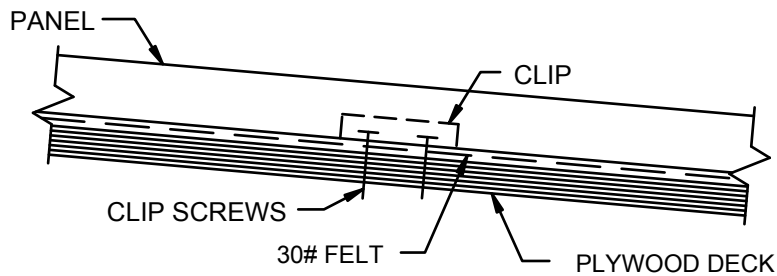

OVER PLYWOOD DECK

RIDGE/HIP DETAIL

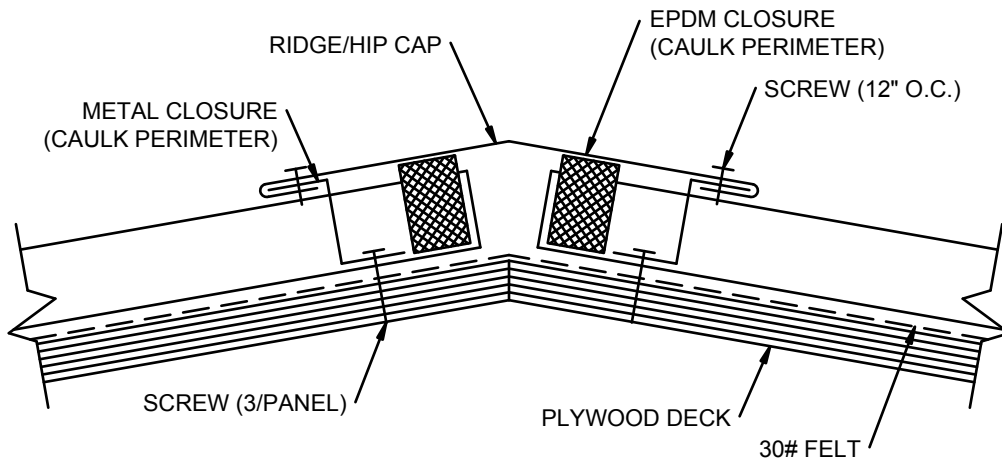

FIXED AT RIDGE OR HIP

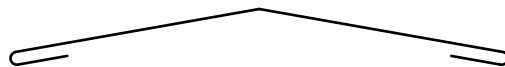

ADD DIMENSIONS TO FLASHING

RIDGE/HIP DETAIL

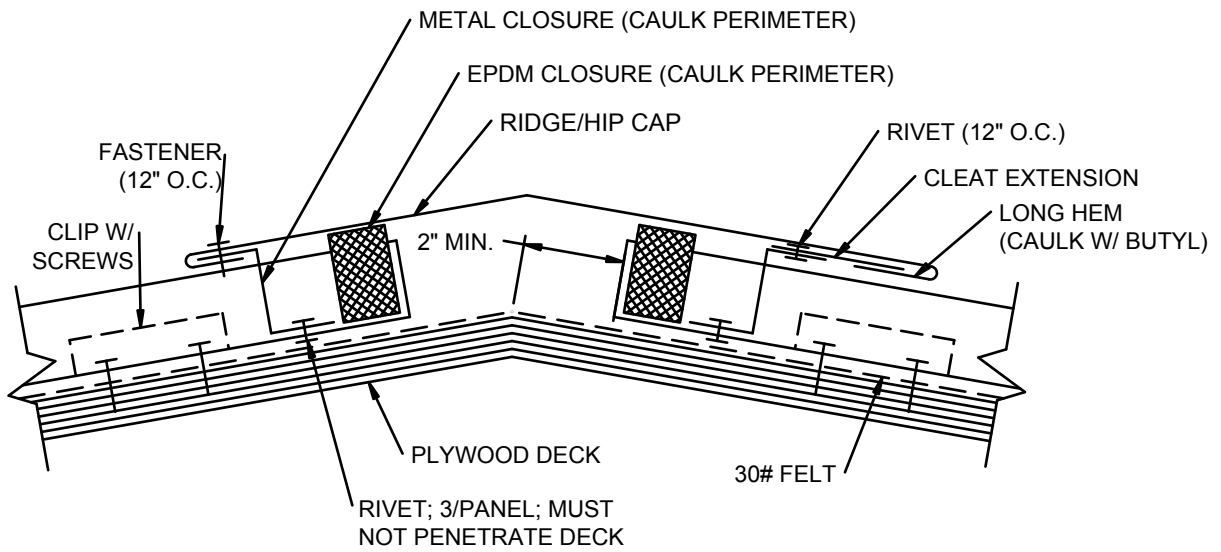

SLIDING AT RIDGE OR HIP

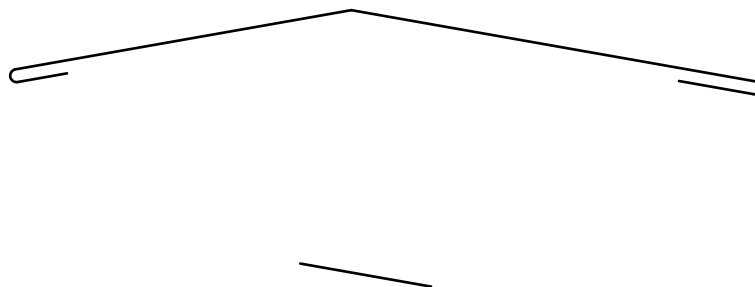

ADD DIMENSIONS TO FLASHINGS

RIDGE/HIP DETAIL

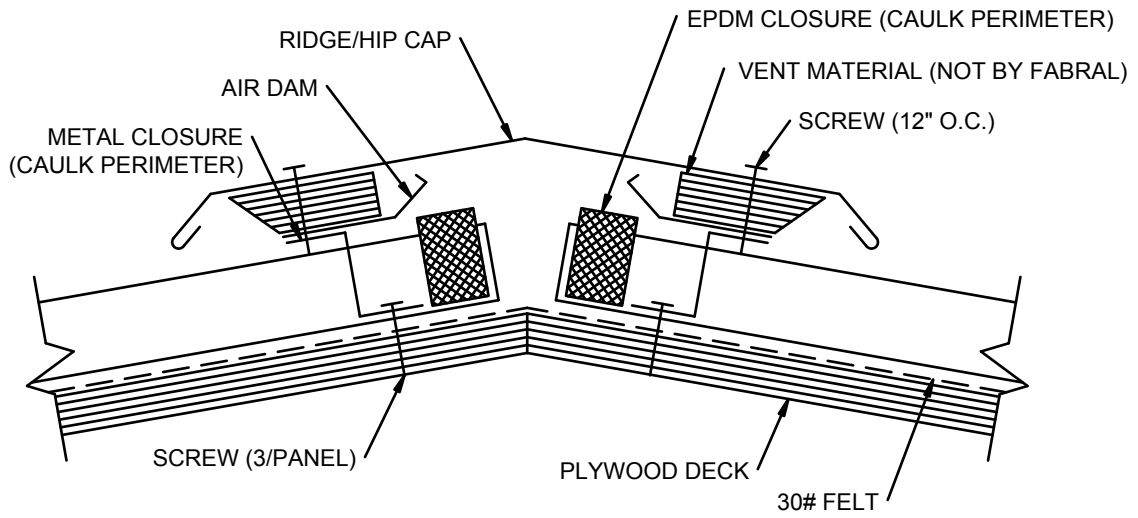

FIXED AT RIDGE OR HIP

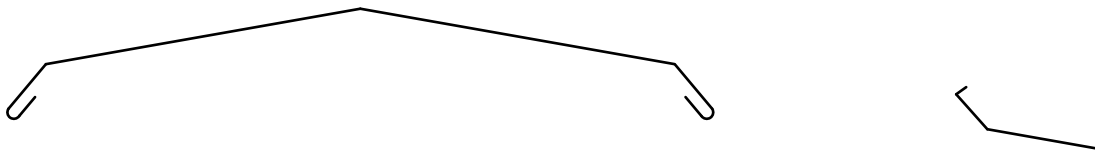

ADD DIMENSIONS TO FLASHINGS

RIDGE/HIP DETAIL

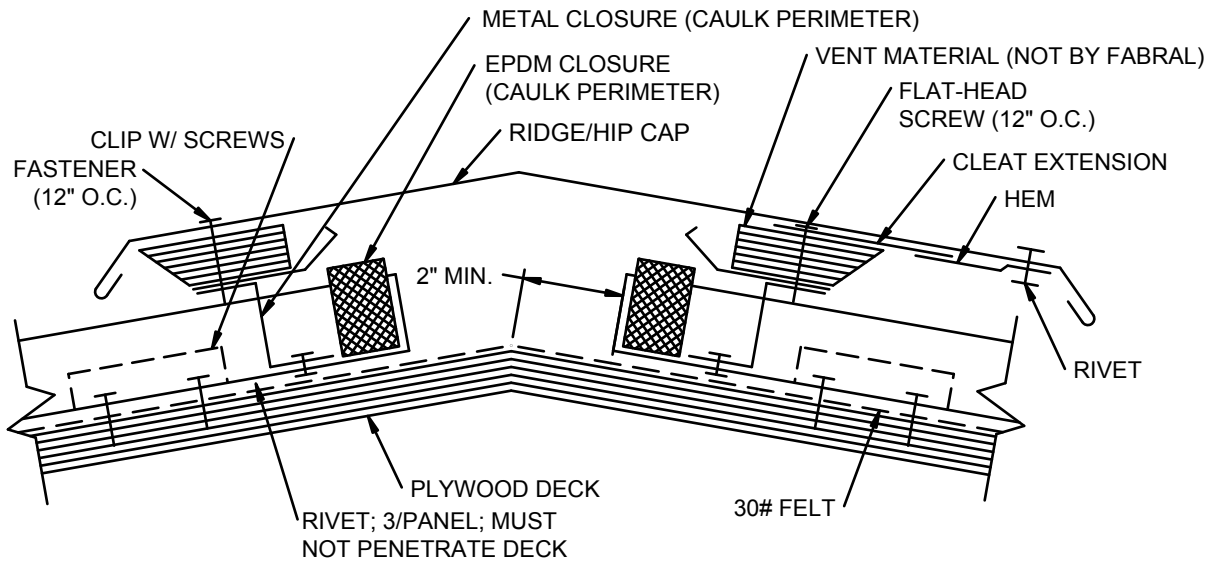

SLIDING AT RIDGE OR HIP

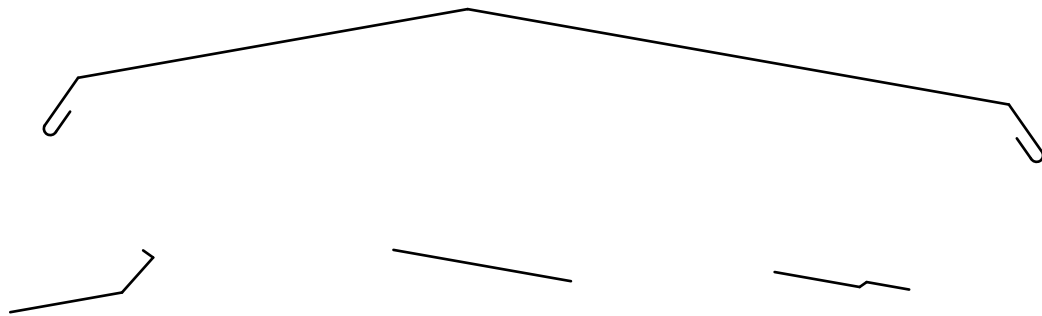

ADD DIMENSIONS TO FLASHINGS

PEAK DETAIL

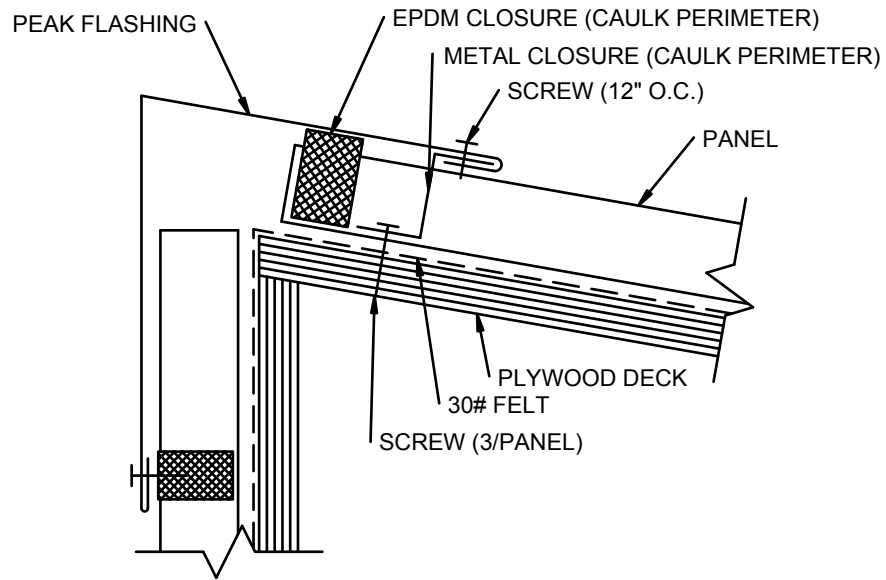

FIXED AT PEAK

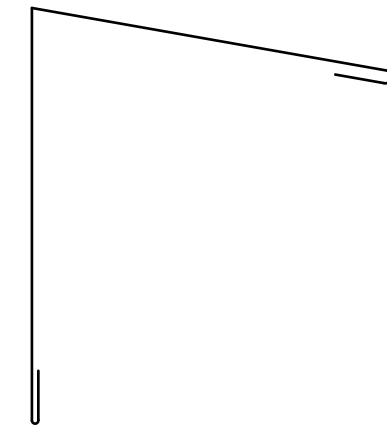

ADD DIMENSIONS TO FLASHING

PEAK DETAIL

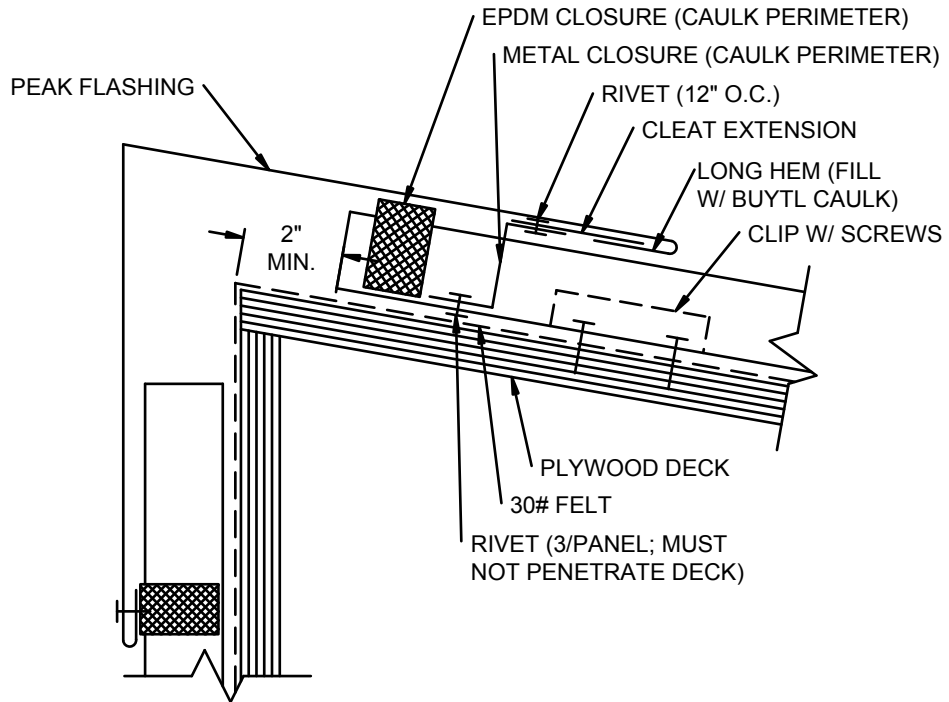

SLIDING AT PEAK

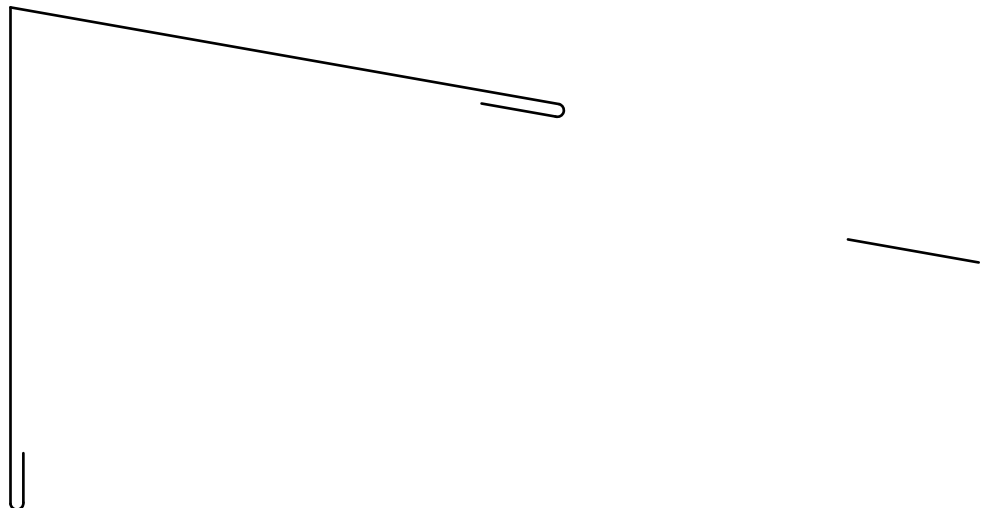

ADD DIMENSIONS TO FLASHINGS

END WALL DETAIL

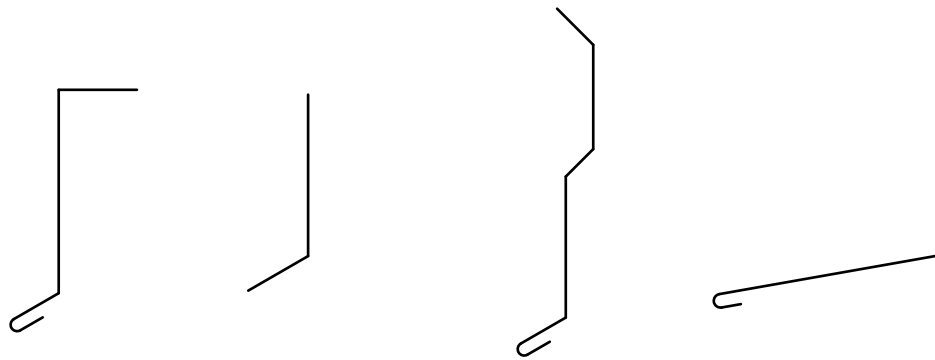
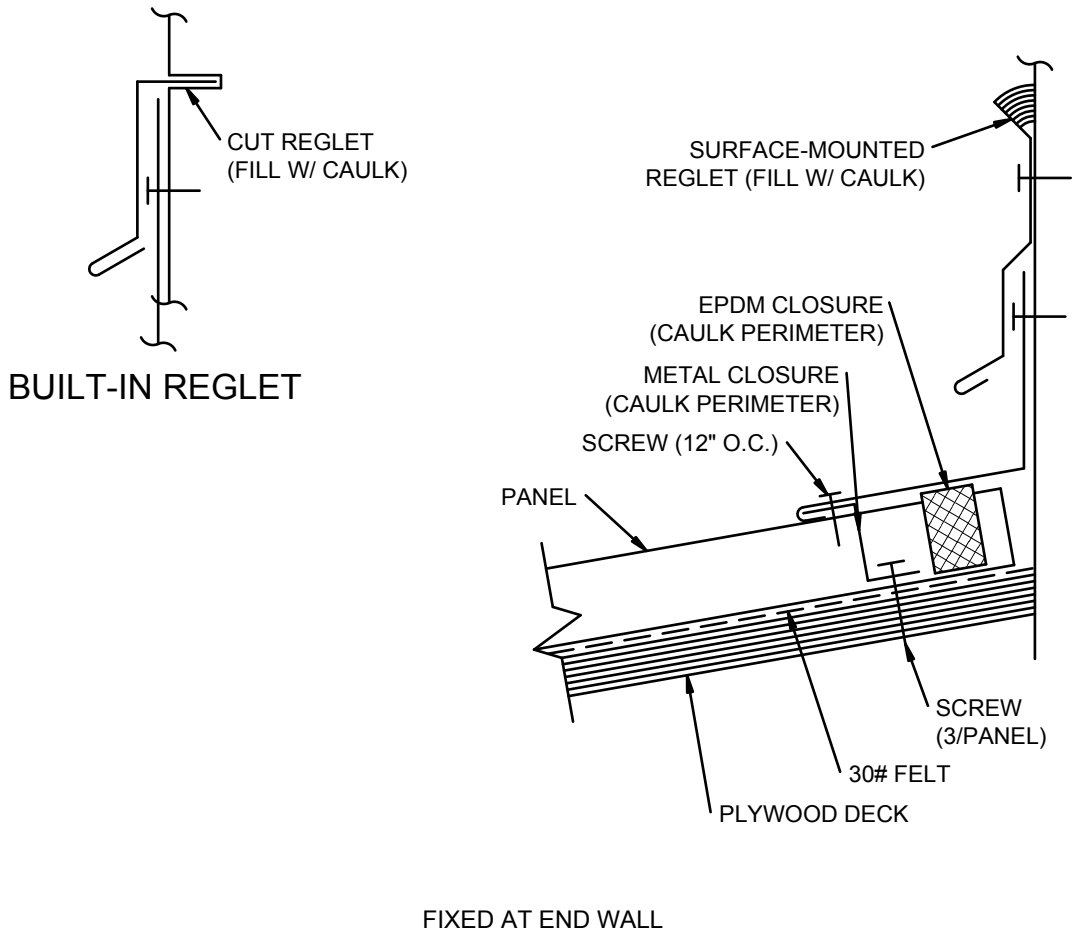

ADD DIMENSIONS TO FLASHINGS

END WALL DETAIL

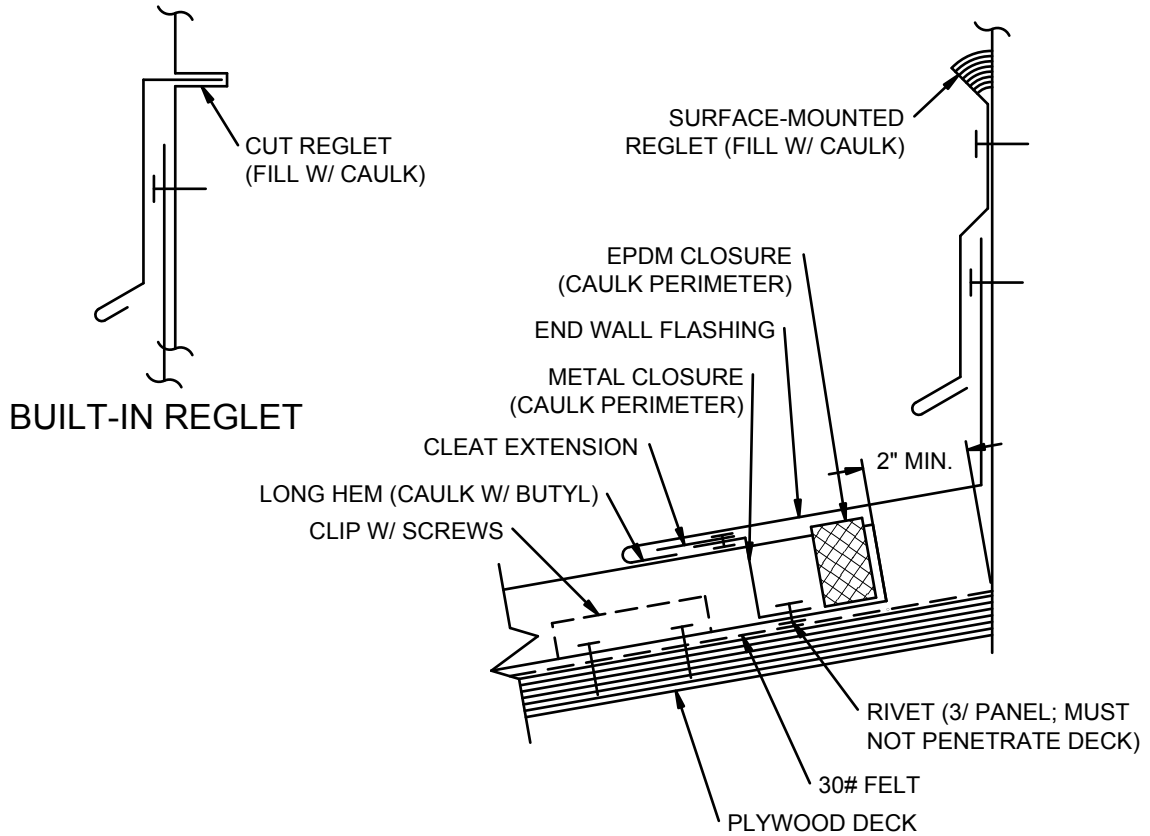

SLIDING AT END WALL

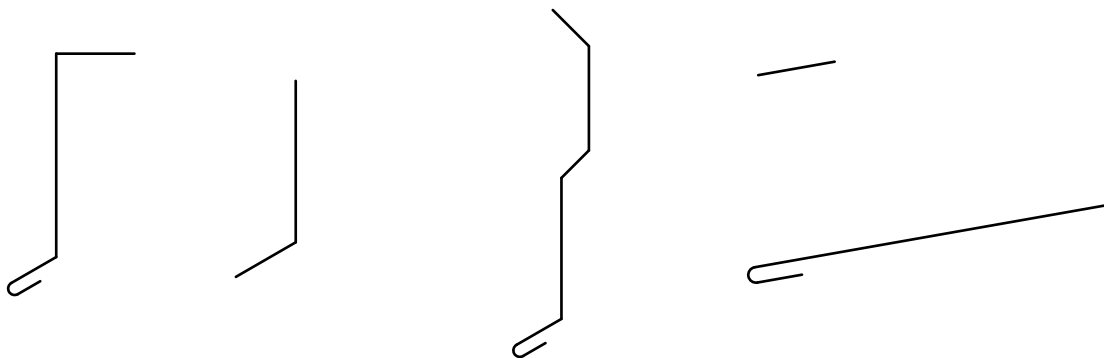

ADD DIMENSIONS TO FLASHINGS

PITCH BREAK DETAIL

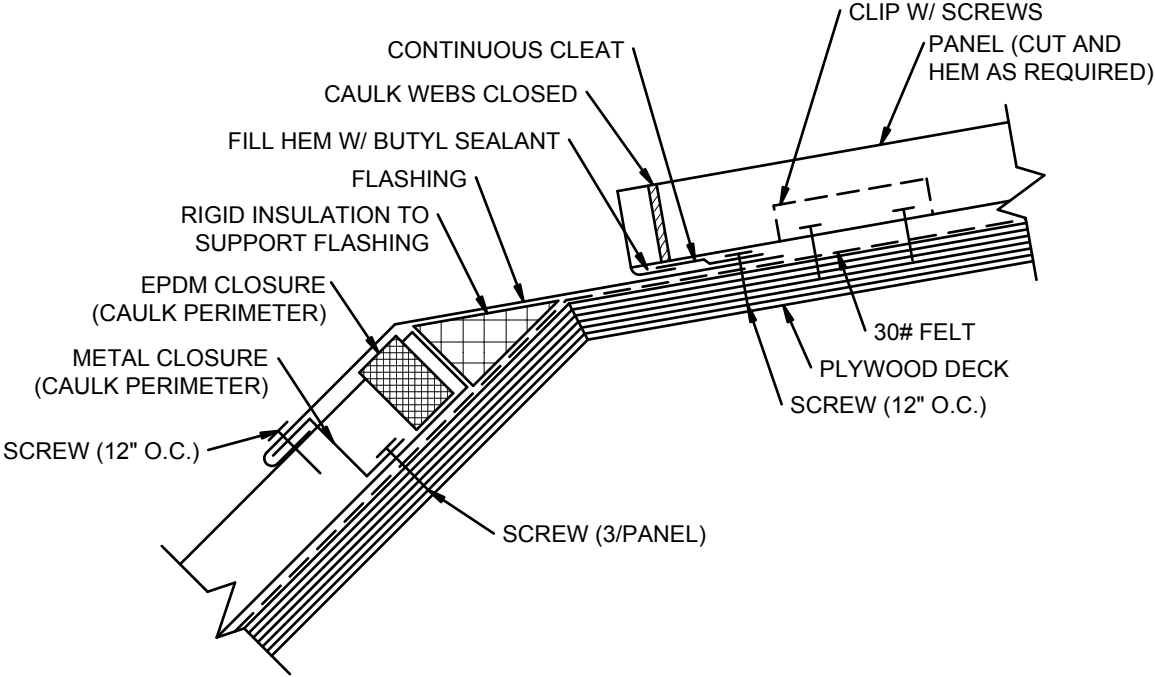

FIXED AT LOWER SIDE OF TRANSITION
SLIDING AT UPPER SIDE OF TRANSITION

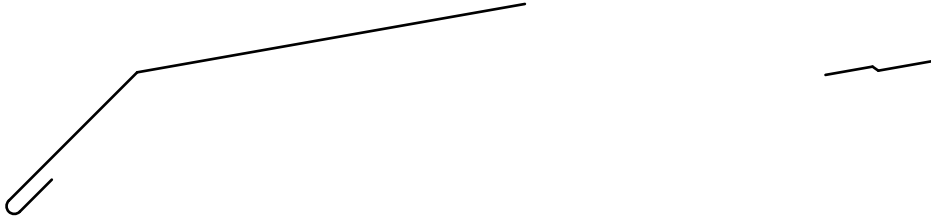

ADD DIMENSIONS TO FLASHINGS

PITCH BREAK DETAIL

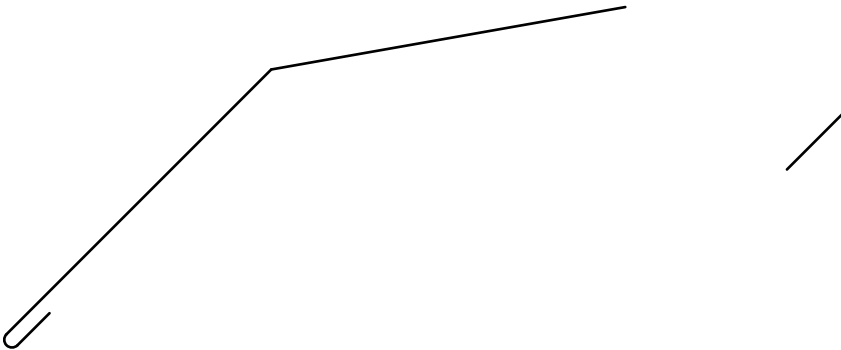
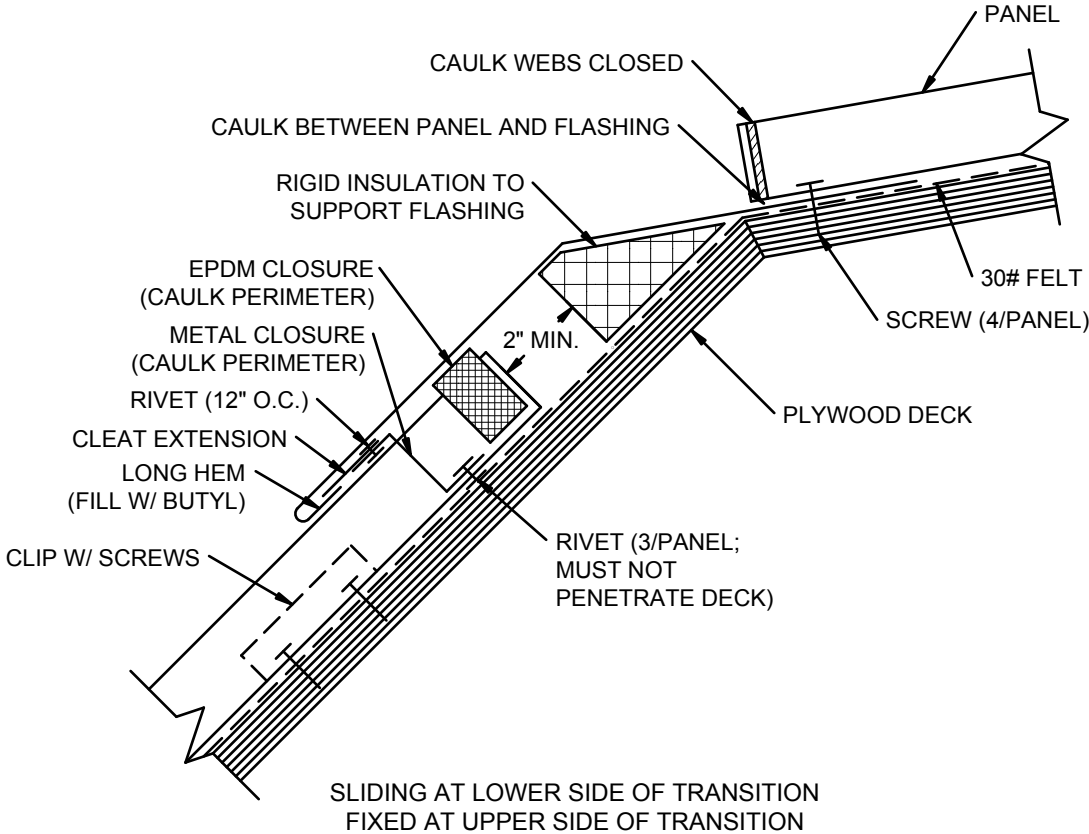

ADD DIMENSIONS TO FLASHINGS

PITCH BREAK DETAIL

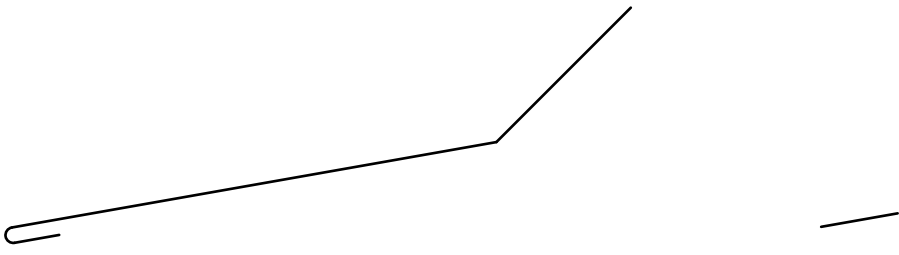
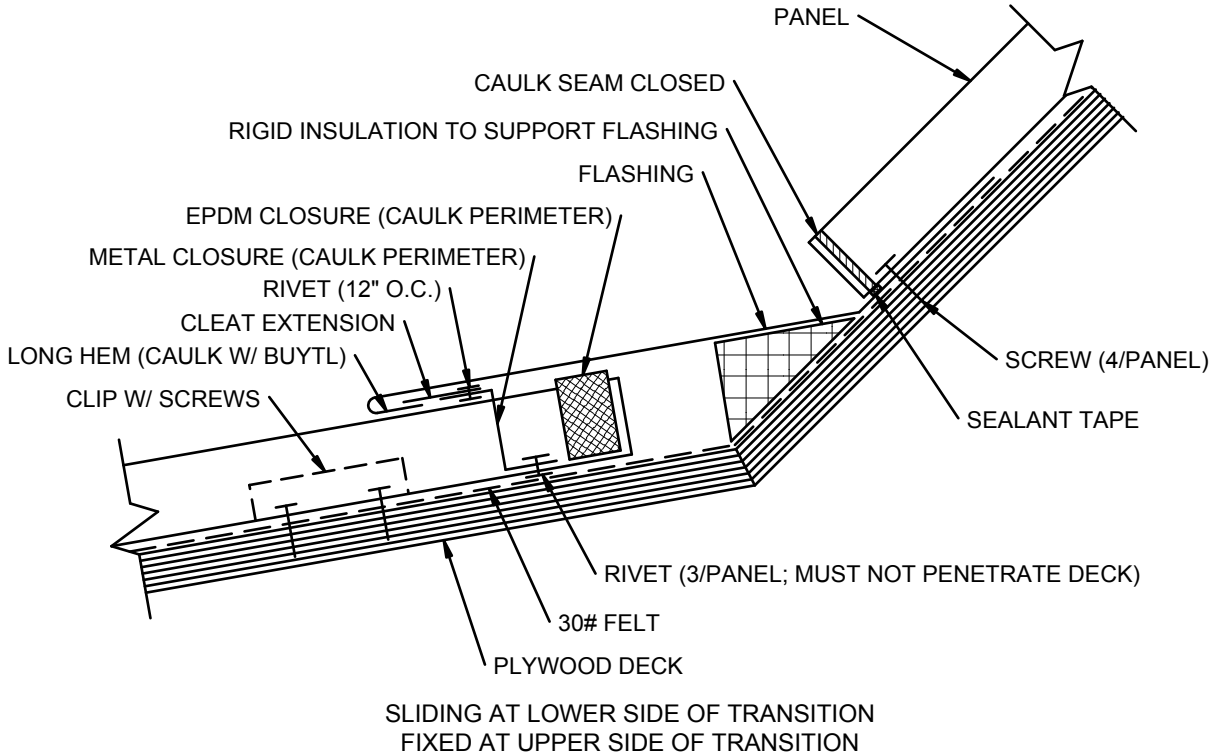

ADD DIMENSIONS TO FLASHINGS

PITCH BREAK DETAIL

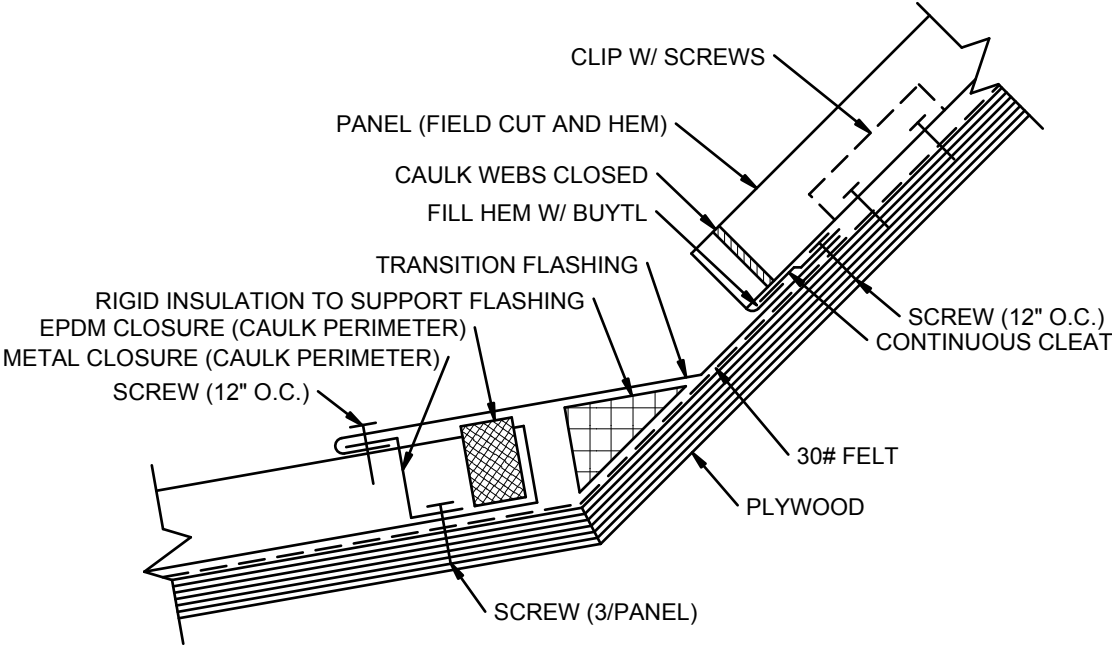

FIXED AT LOWER SIDE OF TRANSITION
 SLIDING AT UPPER SIDE OF TRANSITION

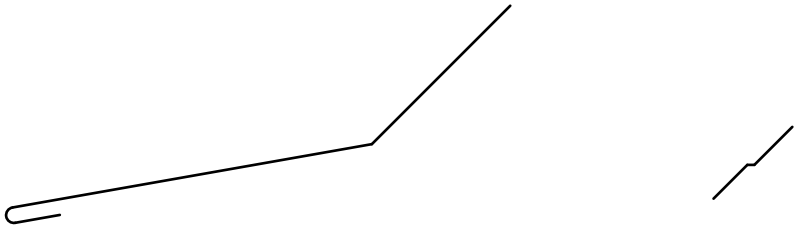

ADD DIMENSIONS TO FLASHINGS

GABLE DETAIL

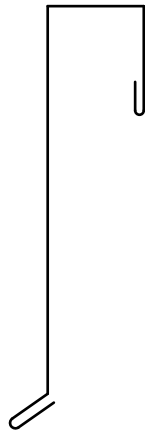
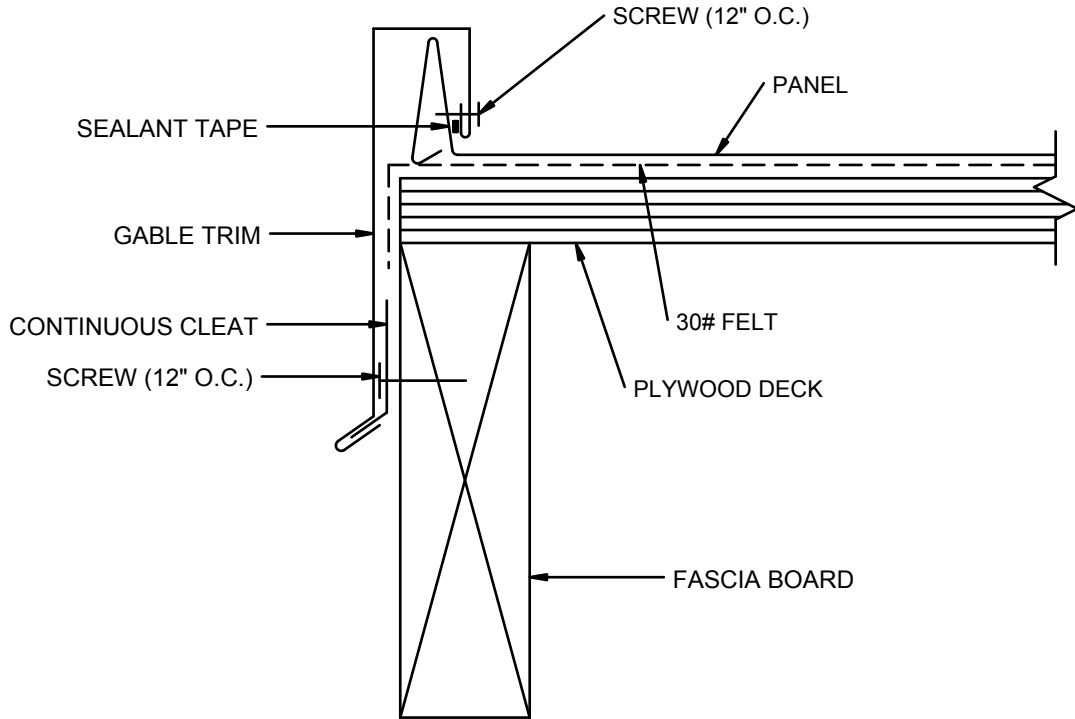

ADD DIMENSIONS TO FLASHINGS

GABLE DETAIL

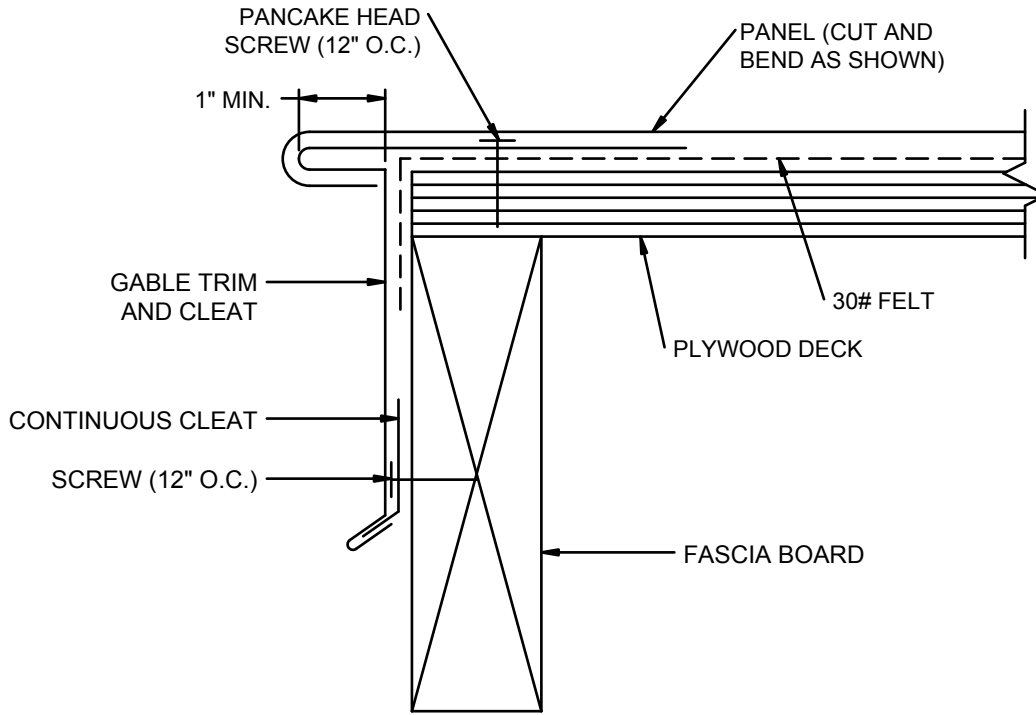

ADD DIMENSIONS TO FLASHINGS

GABLE DETAIL

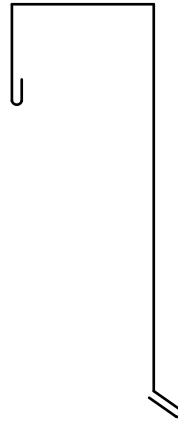
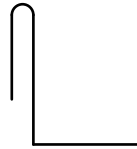
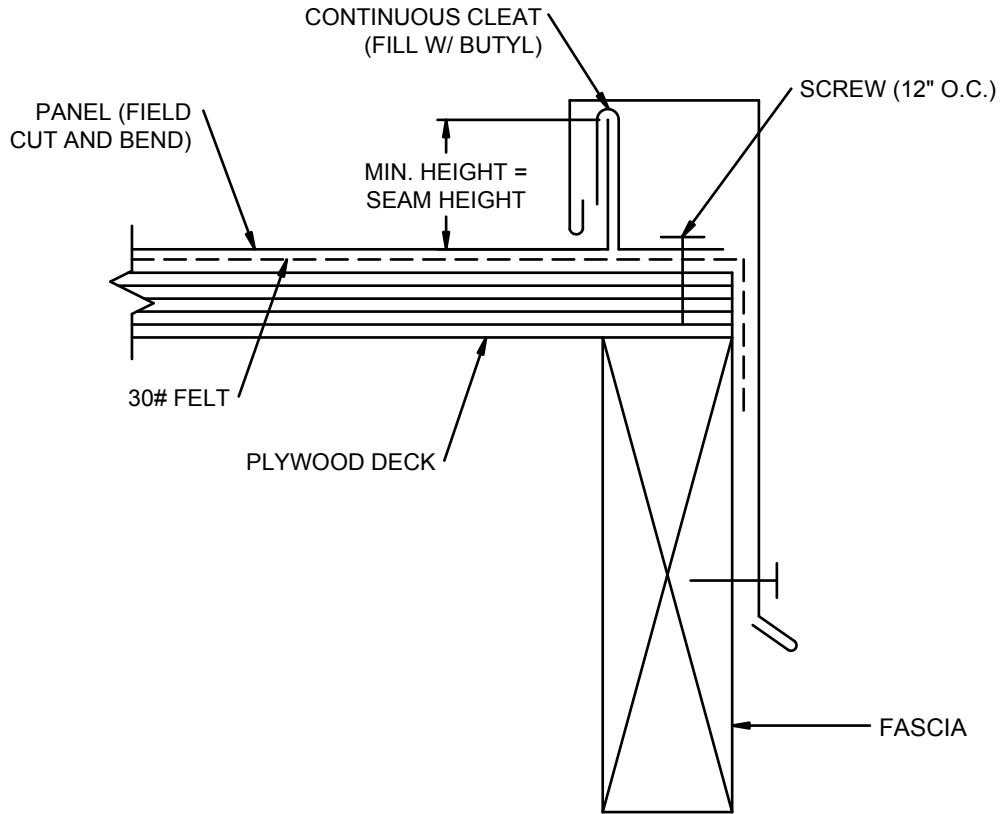

ADD DIMENSIONS TO FLASHINGS

SIDEWALL DETAIL

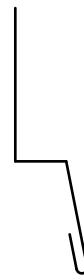
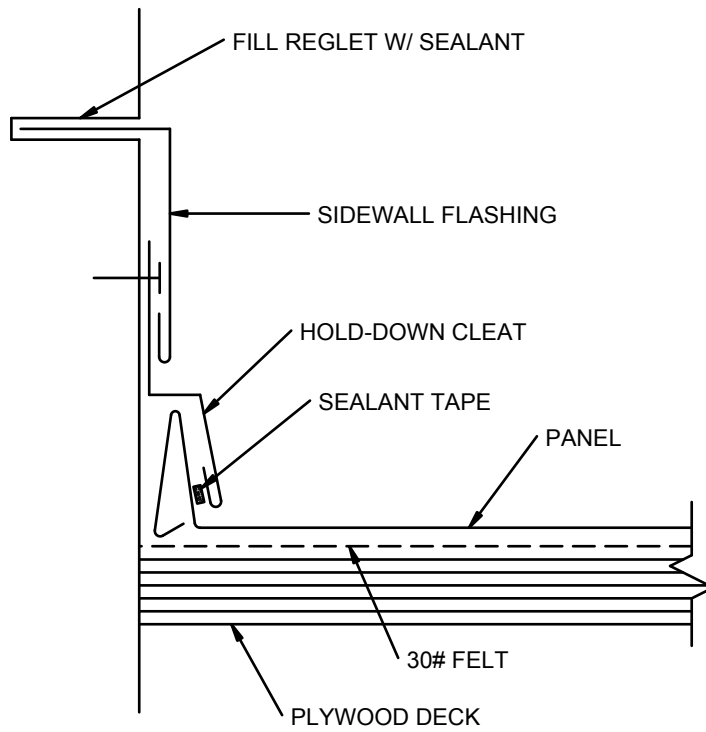

ADD DIMENSIONS TO FLASHINGS

SIDEWALL DETAIL

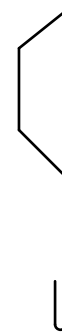
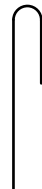
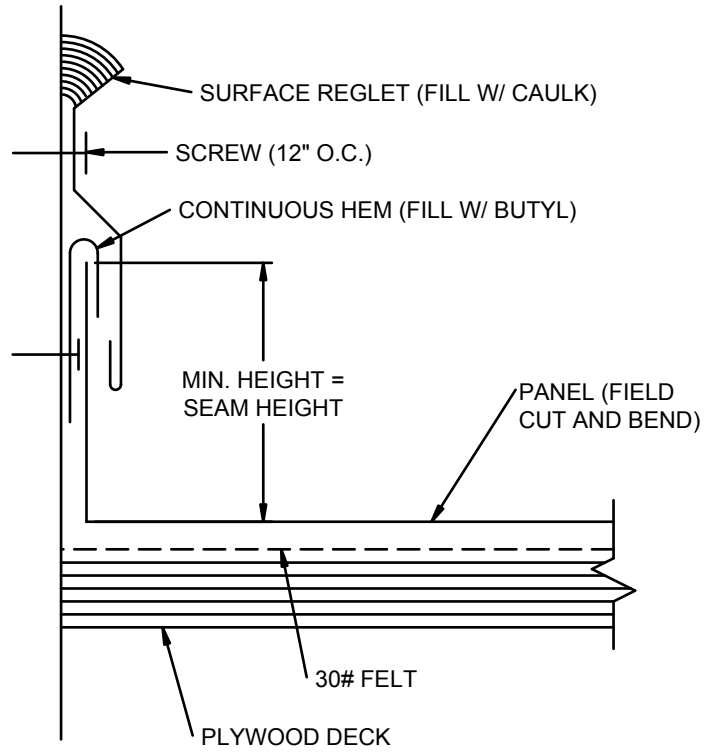

ADD DIMENSIONS TO FLASHINGS

EAVE DETAIL

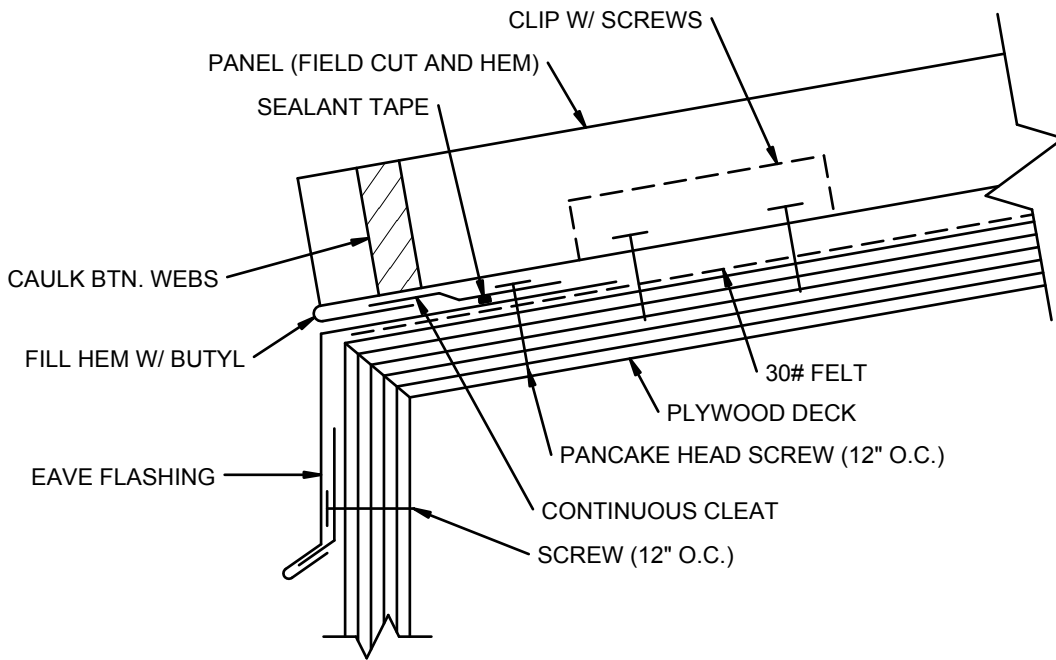

SLIDING AT EAVE

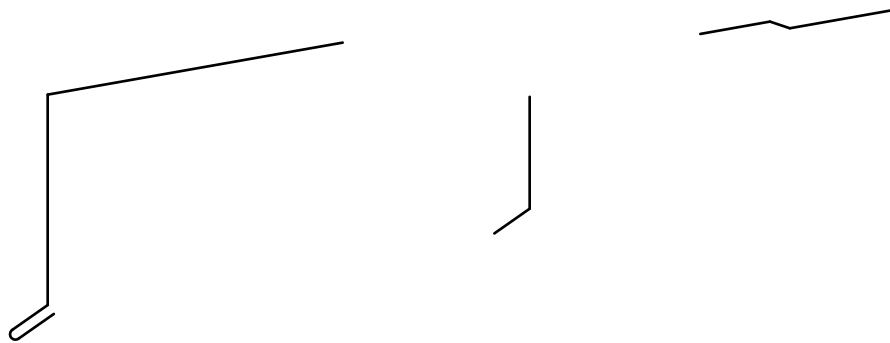

ADD DIMENSIONS TO FLASHINGS

EAVE DETAIL

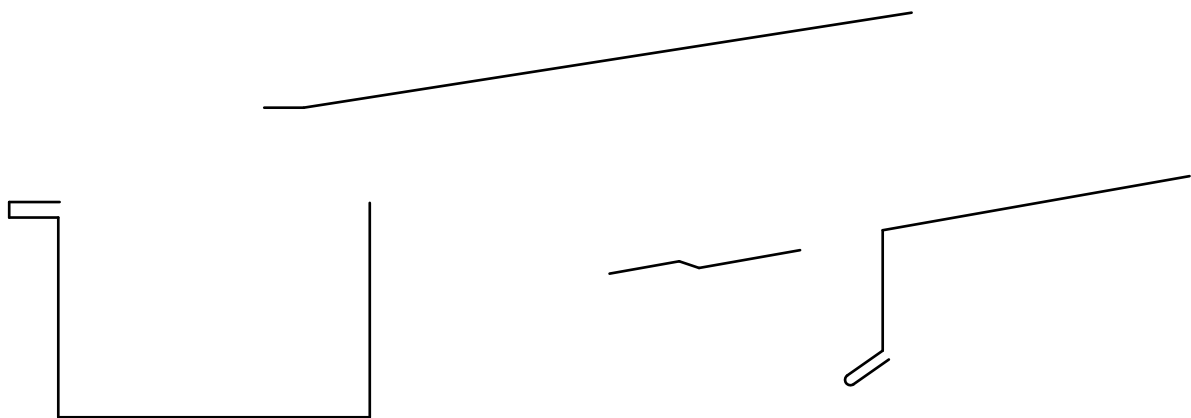
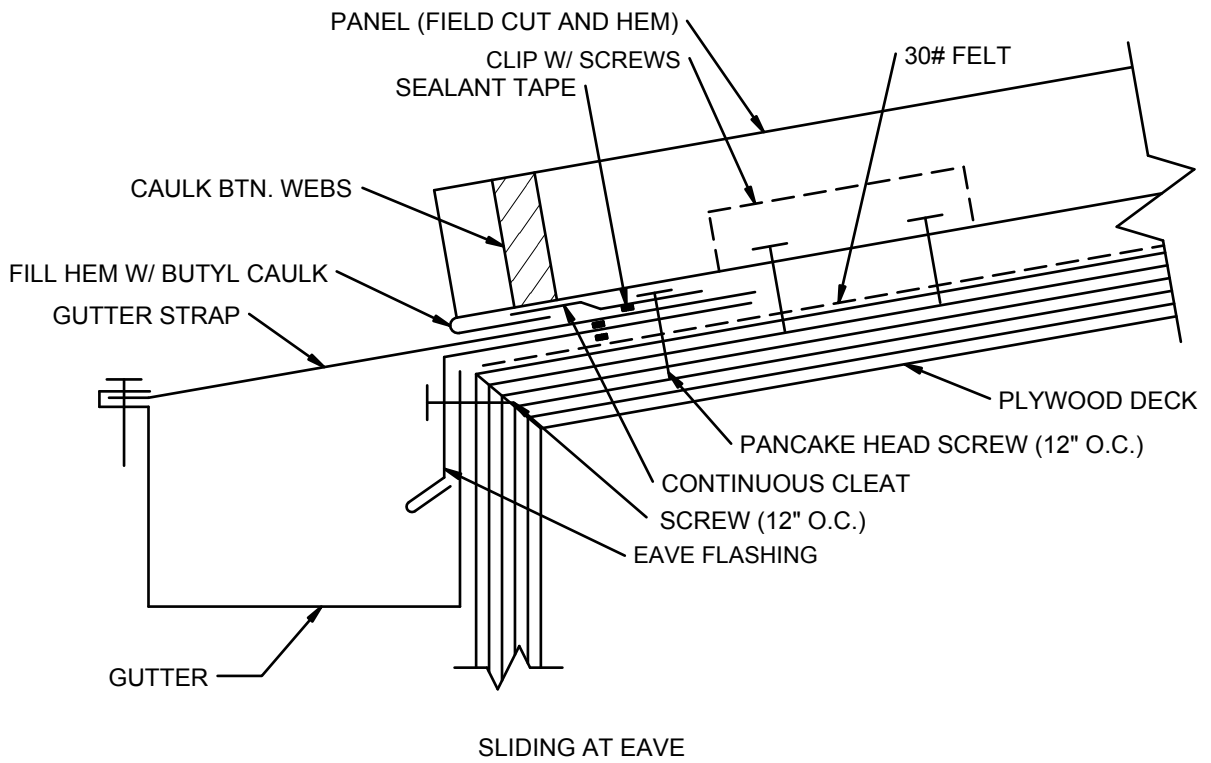

ADD DIMENSIONS TO FLASHINGS

EAVE DETAIL

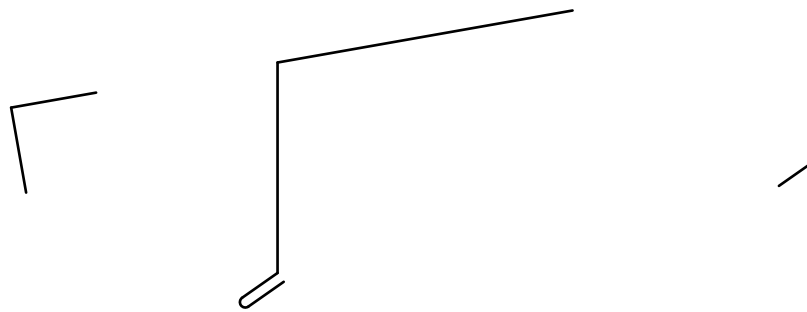
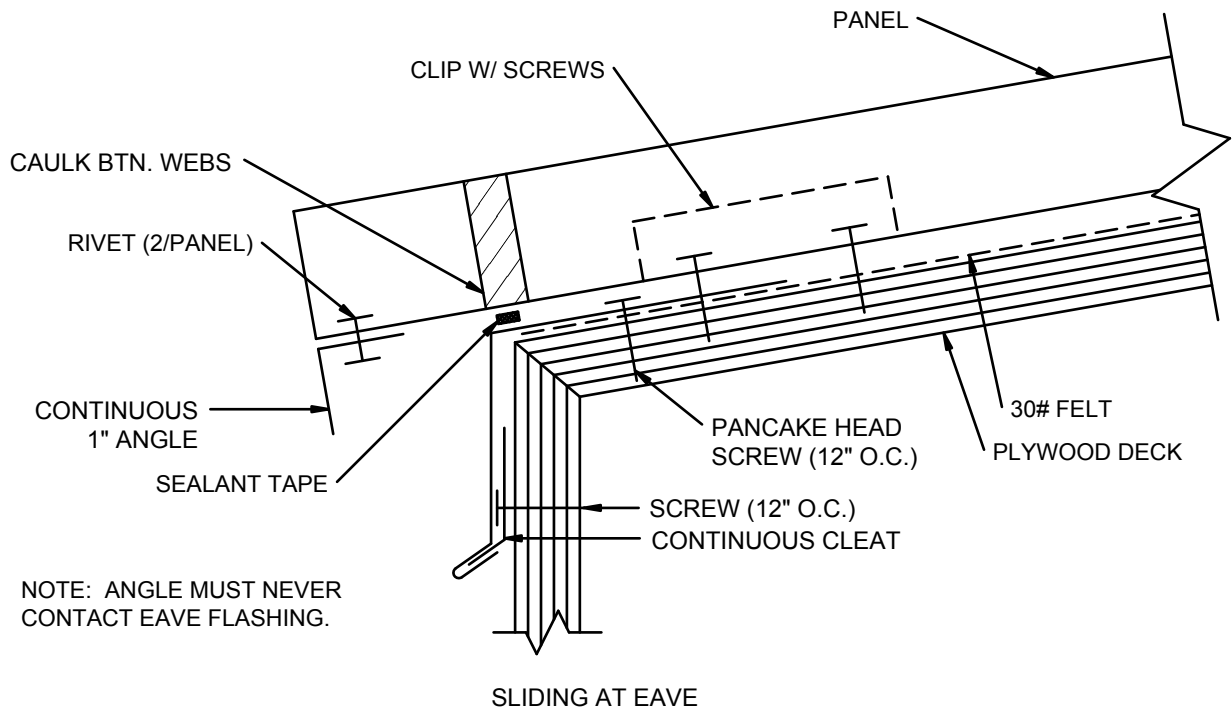

ADD DIMENSIONS TO FLASHINGS

EAVE DETAIL

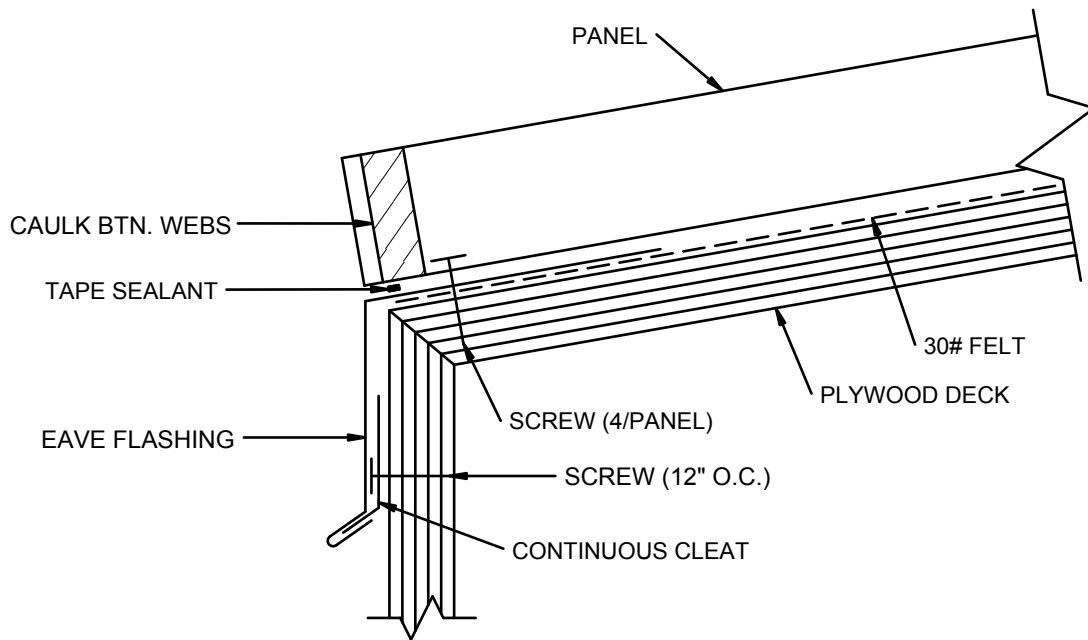

FIXED AT EAVE

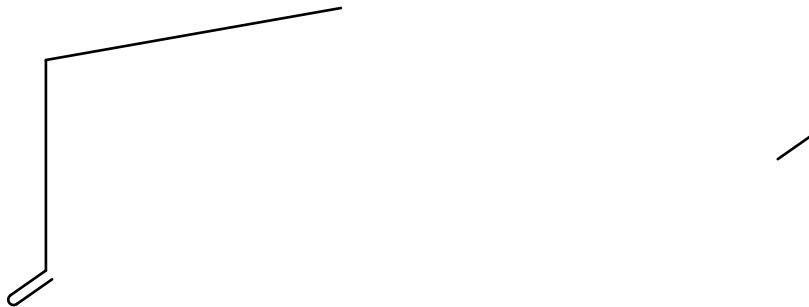

ADD DIMENSIONS TO FLASHINGS

EAVE DETAIL

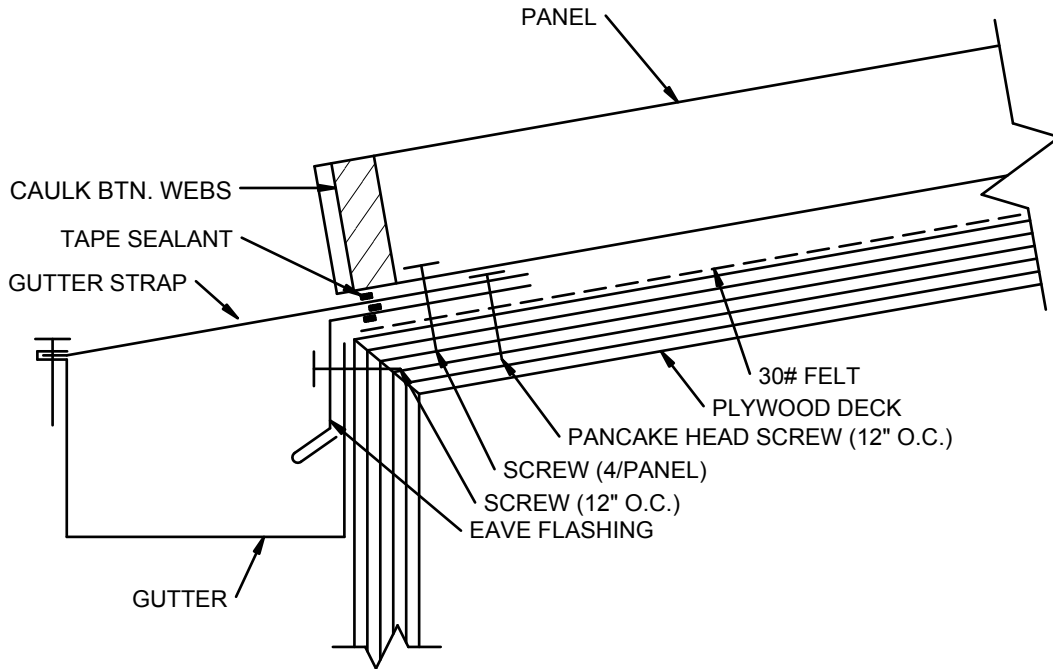

FIXED AT EAVE

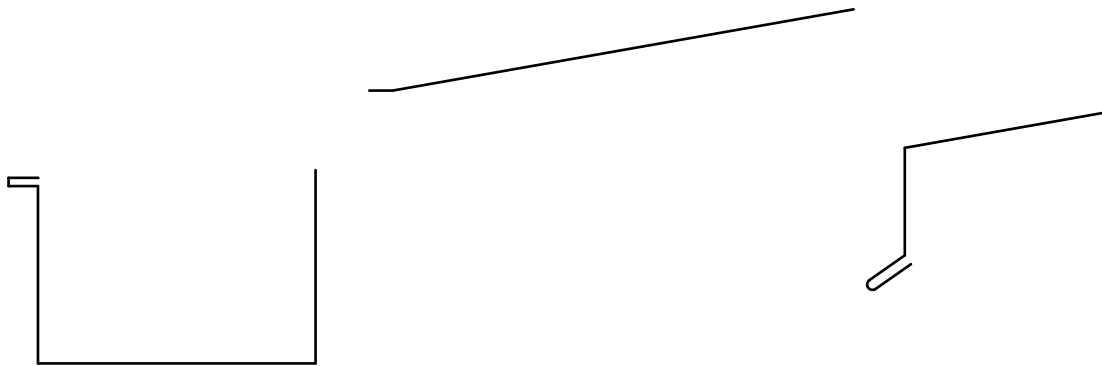

ADD DIMENSIONS TO FLASHINGS

GUTTER EXPANSION JOINT

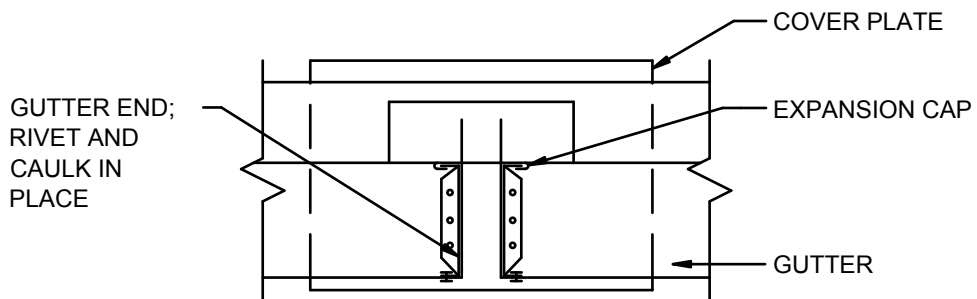
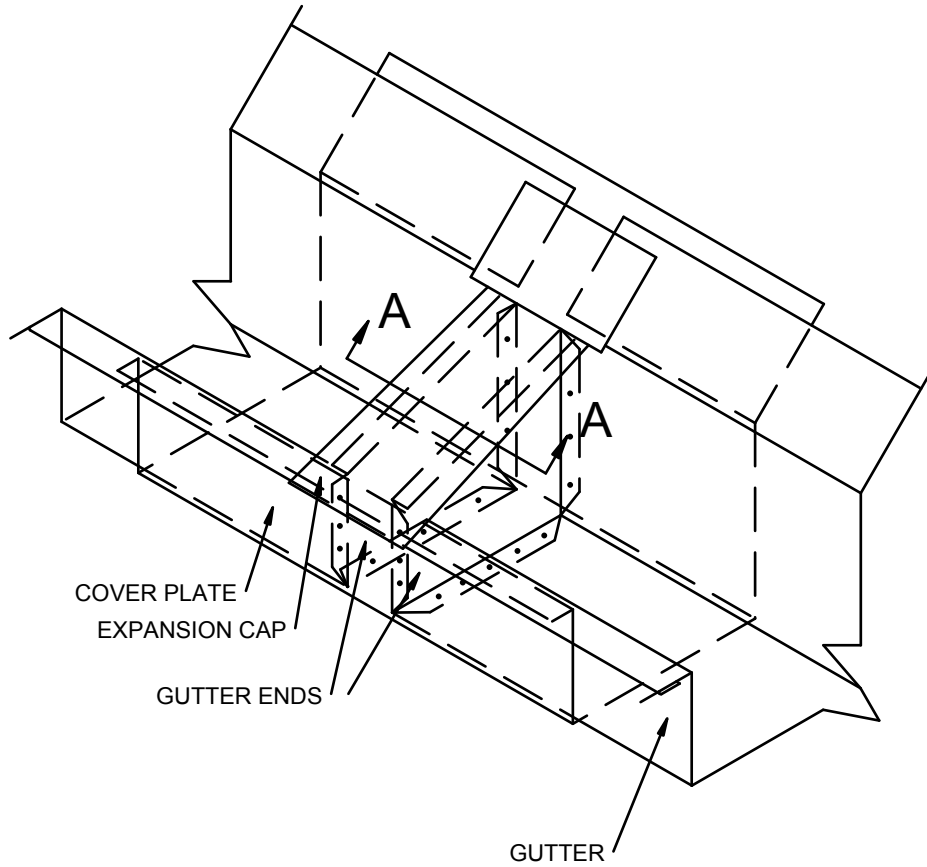

SECTION A-A

VALLEY DETAIL

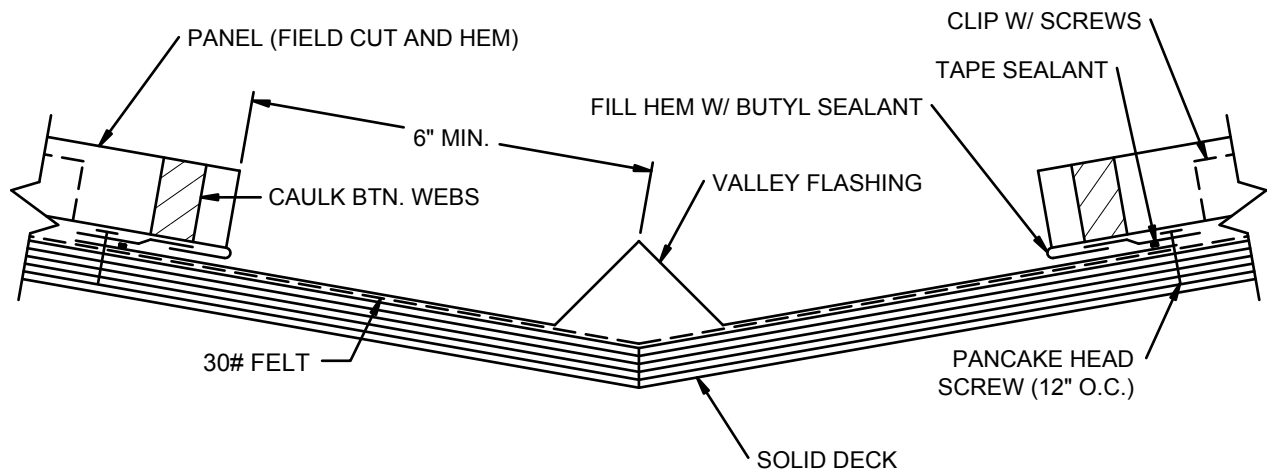

SLIDING AT VALLEY

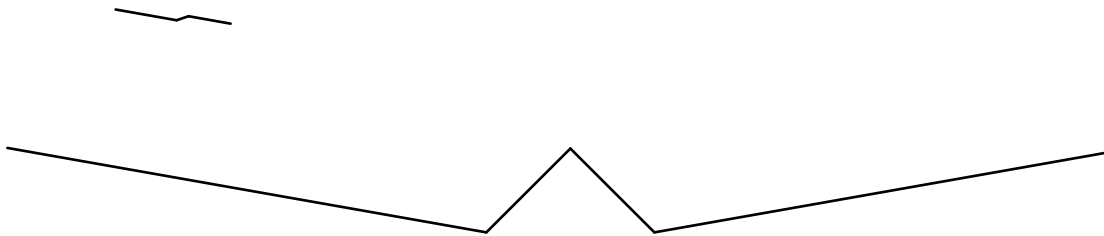

ADD DIMENSIONS TO FLASHINGS

VALLEY DETAIL

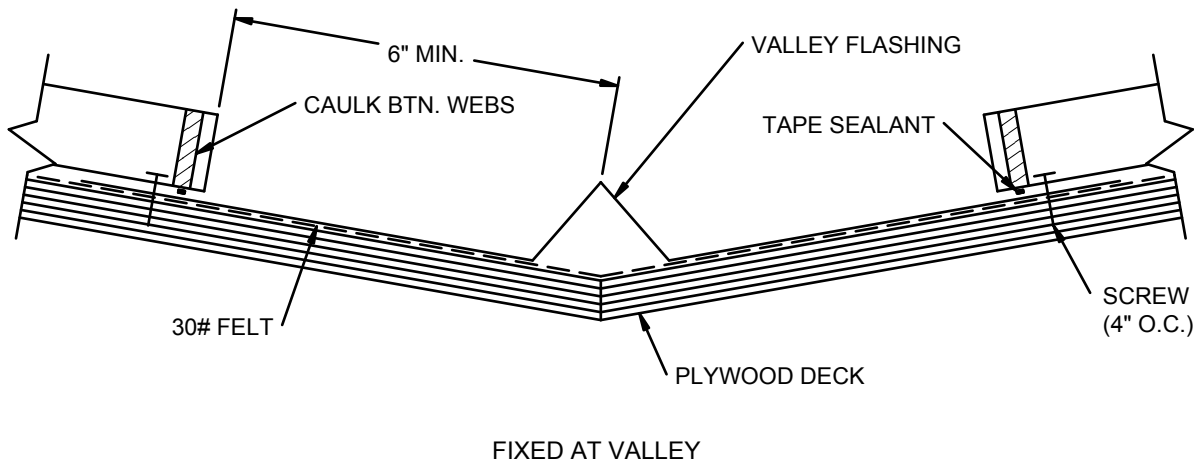

ADD DIMENSIONS TO FLASHING

ROOF/FASCIA TRANSITION

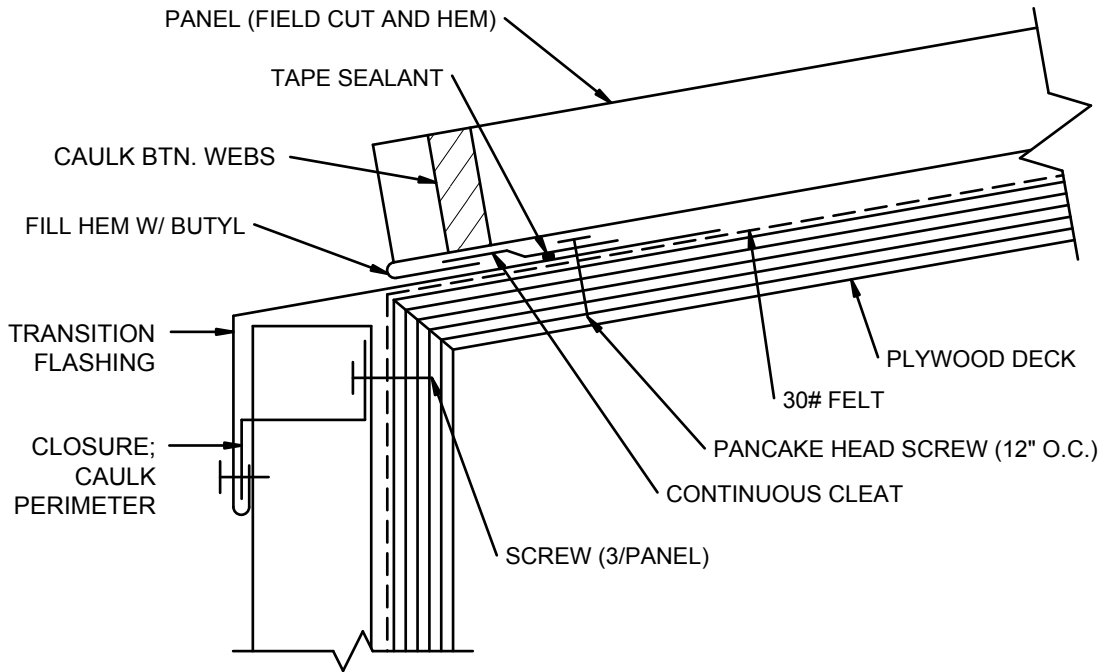

SLIDING ROOF PANEL AT TRANSITION, FIXED FASCIA PANEL AT TRANSITION

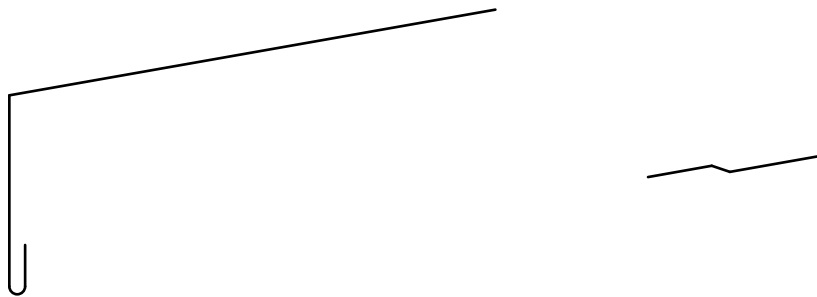

ADD DIMENSIONS TO FLASHINGS

ROOF/FASCIA TRANSITION

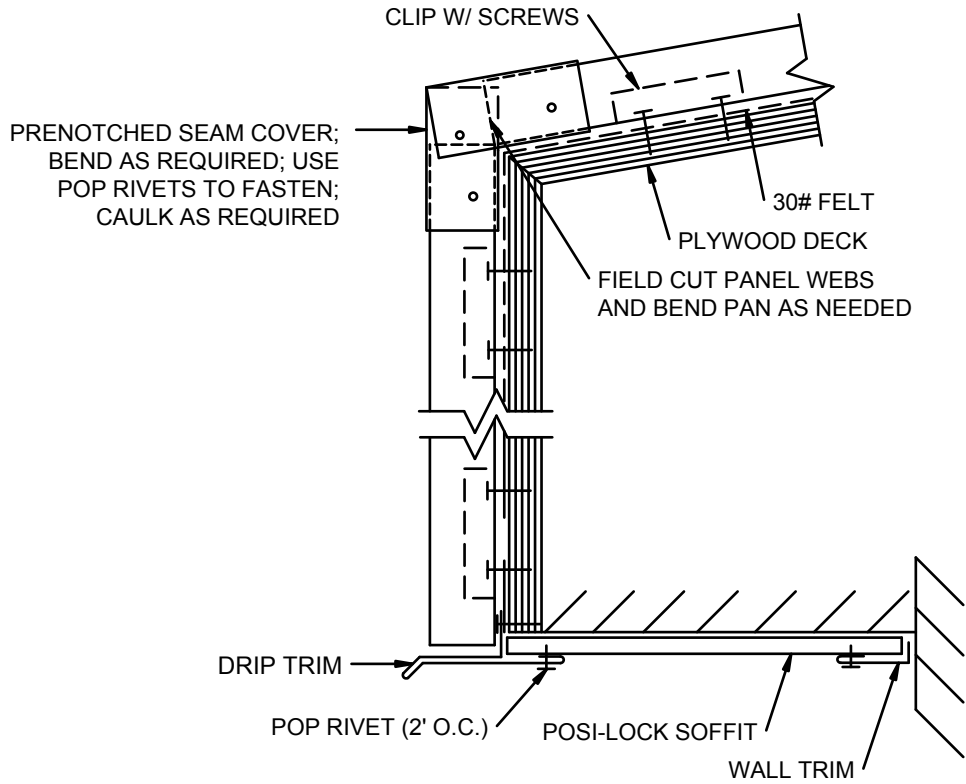

FIXED AT TRANSITION; REQUIRES SLIDING
RIDGE/HIP AND SLIDING END

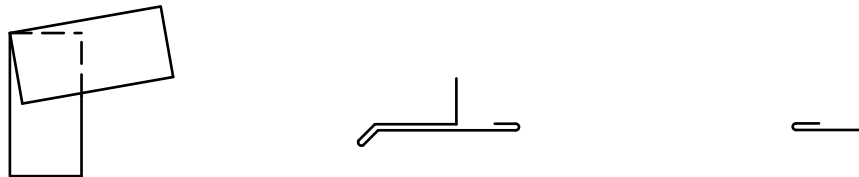

ADD DIMENSIONS TO FLASHINGS

ROOF/FASCIA TRANSITION

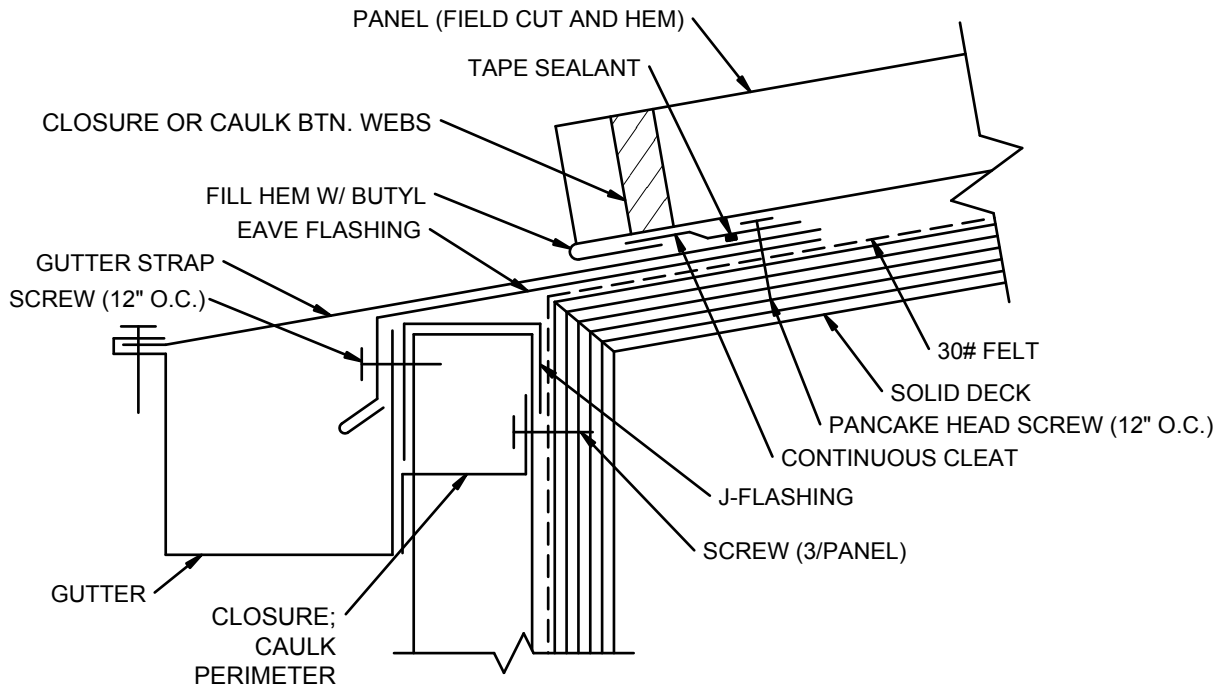

SLIDING ROOF PANEL AT TRANSITION, FIXED FASCIA PANEL AT TRANSITION

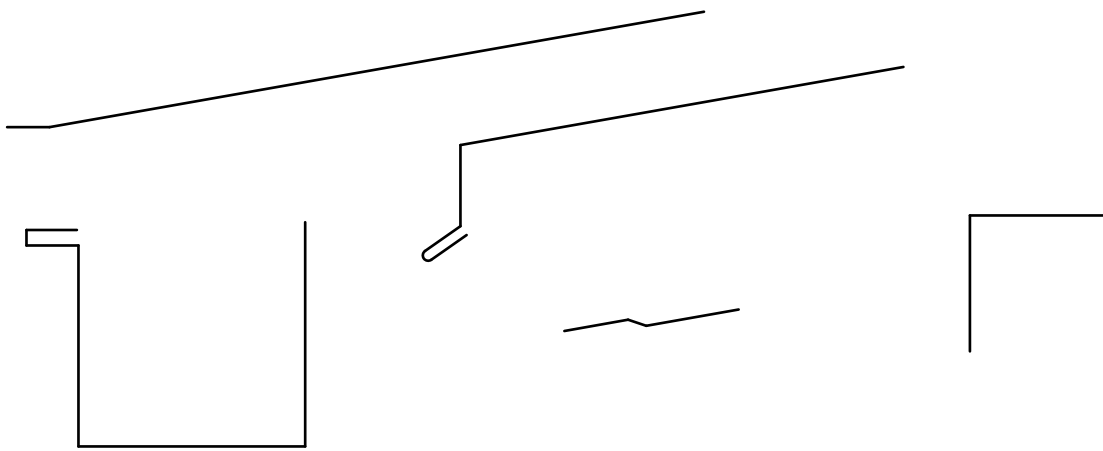

ADD DIMENSIONS TO FLASHINGS

FASCIA OUTSIDE CORNER

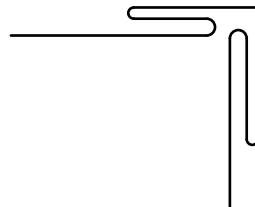
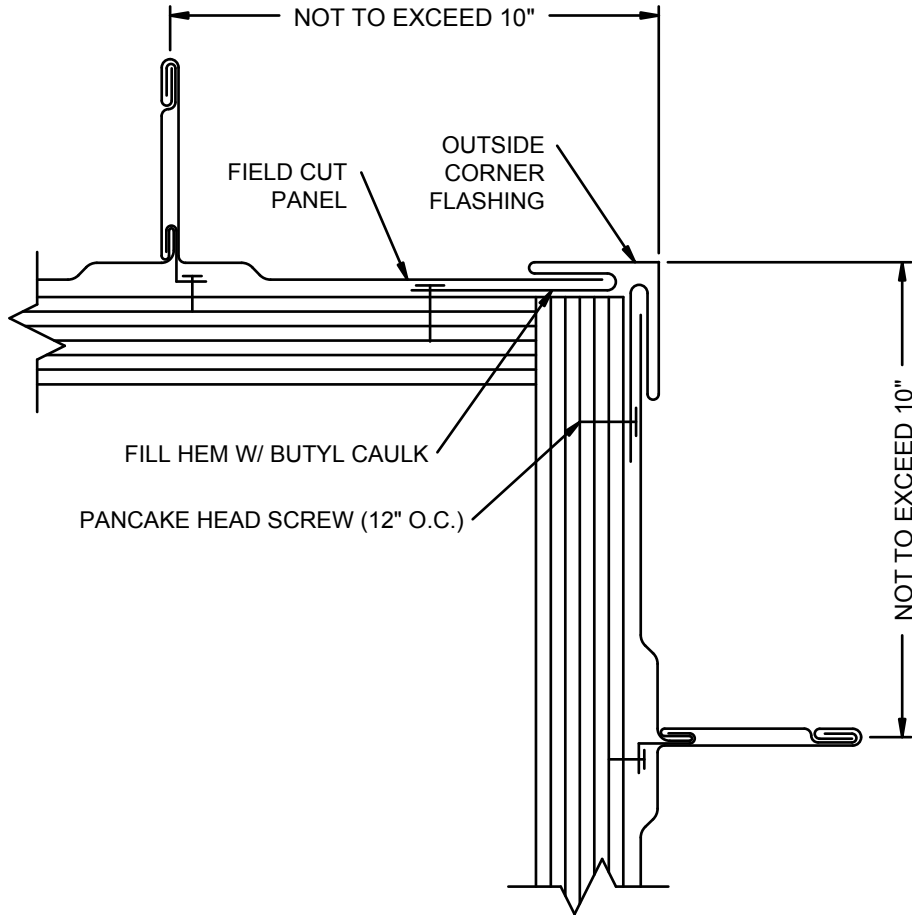

ADD DIMENSIONS TO FLASHING

FASCIA INSIDE CORNER

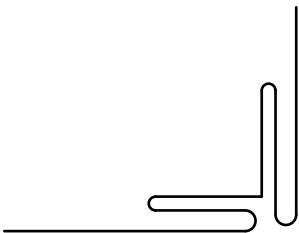
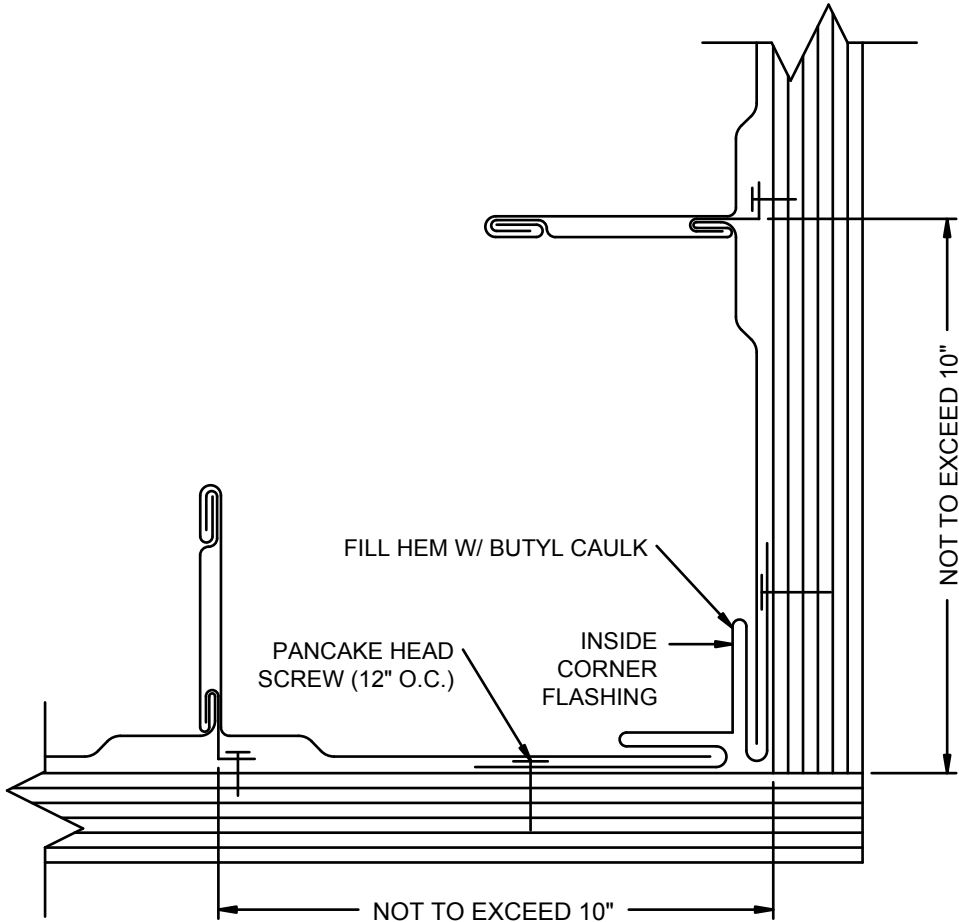

ADD DIMENSIONS TO FLASHING

FASCIA EDGE

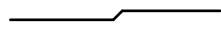
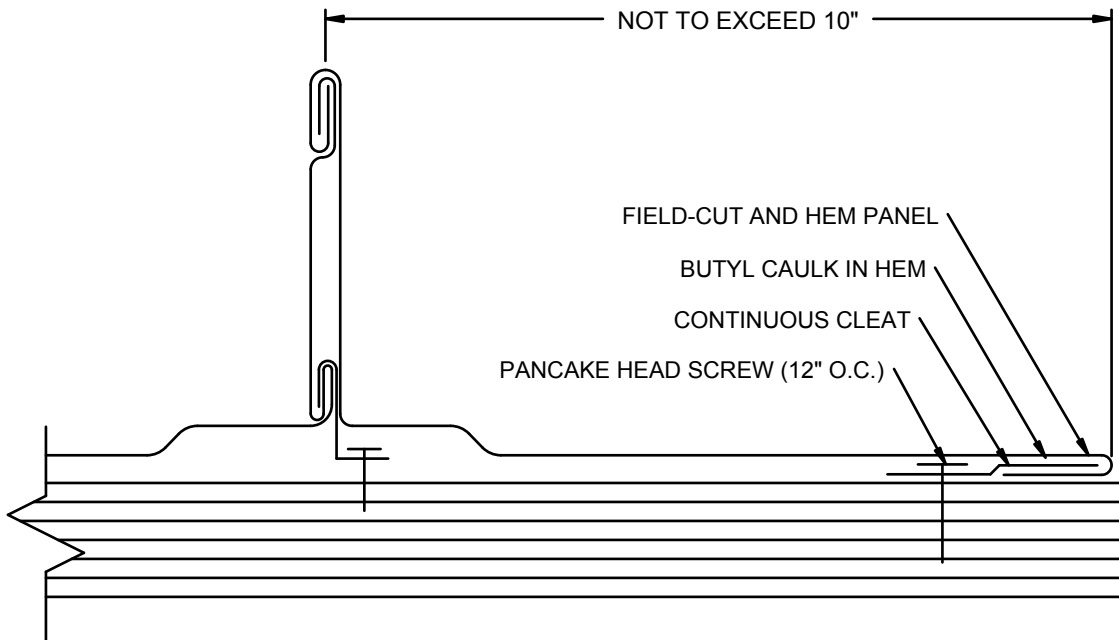

ADD DIMENSIONS TO FLASHING

PIPE BOOT PENETRATION

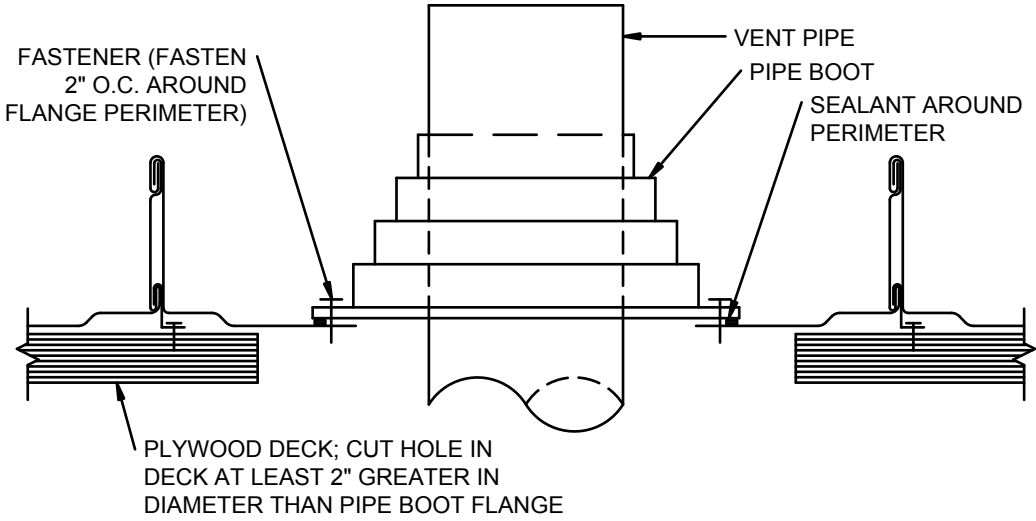

VENT PIPE FLASHING
(ALSO APPLIES TO LIGHT
EQUIPMENT CURBS)

CURB PENETRATION

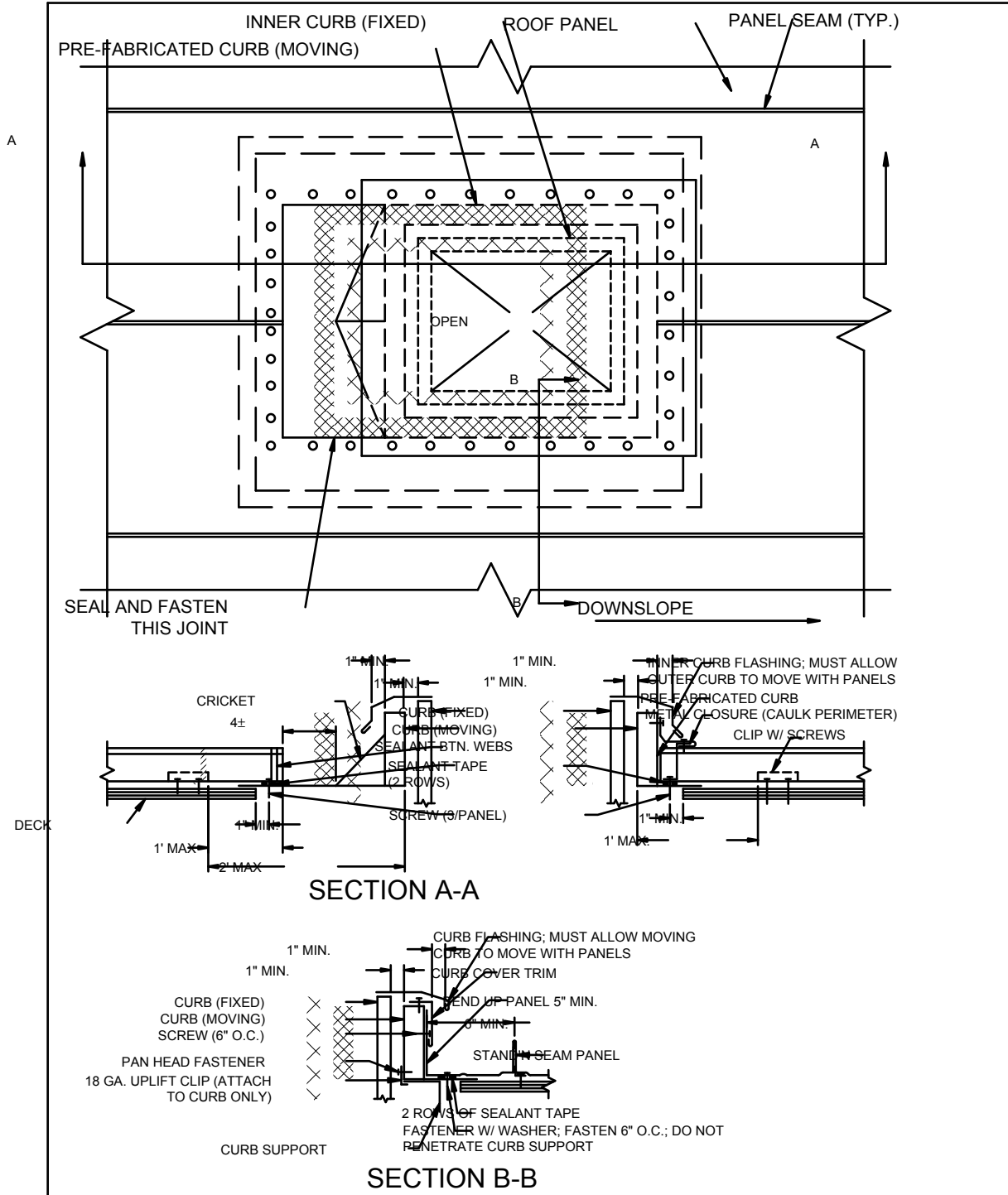

CONSTRUCTION JOINT

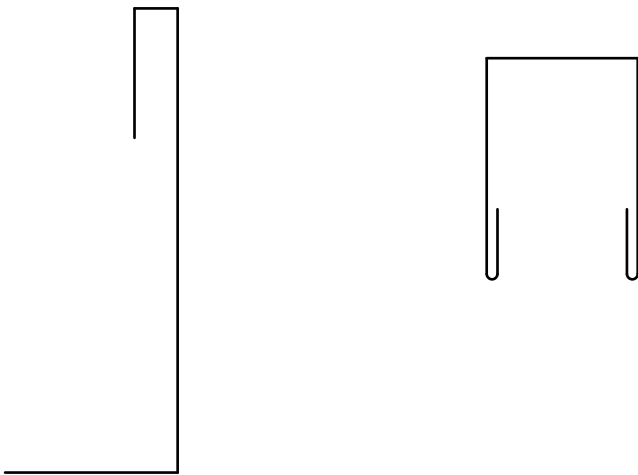
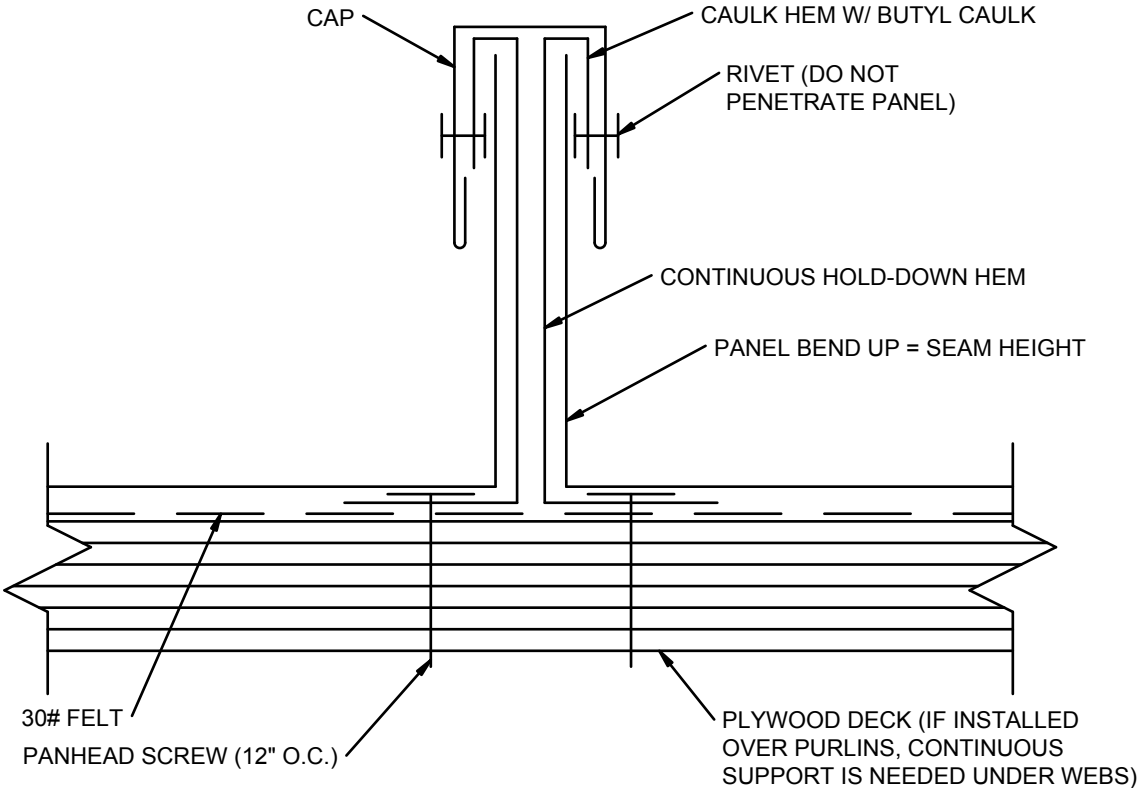

ADD DIMENSIONS TO FLASHINGS

CONSTRUCTION JOINT

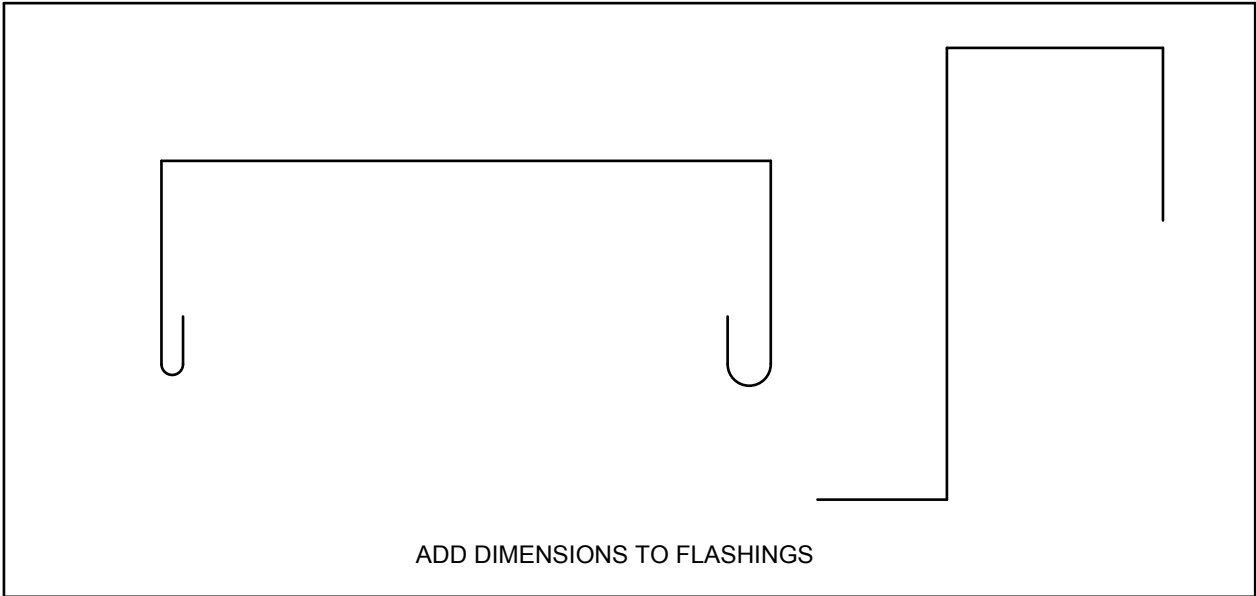
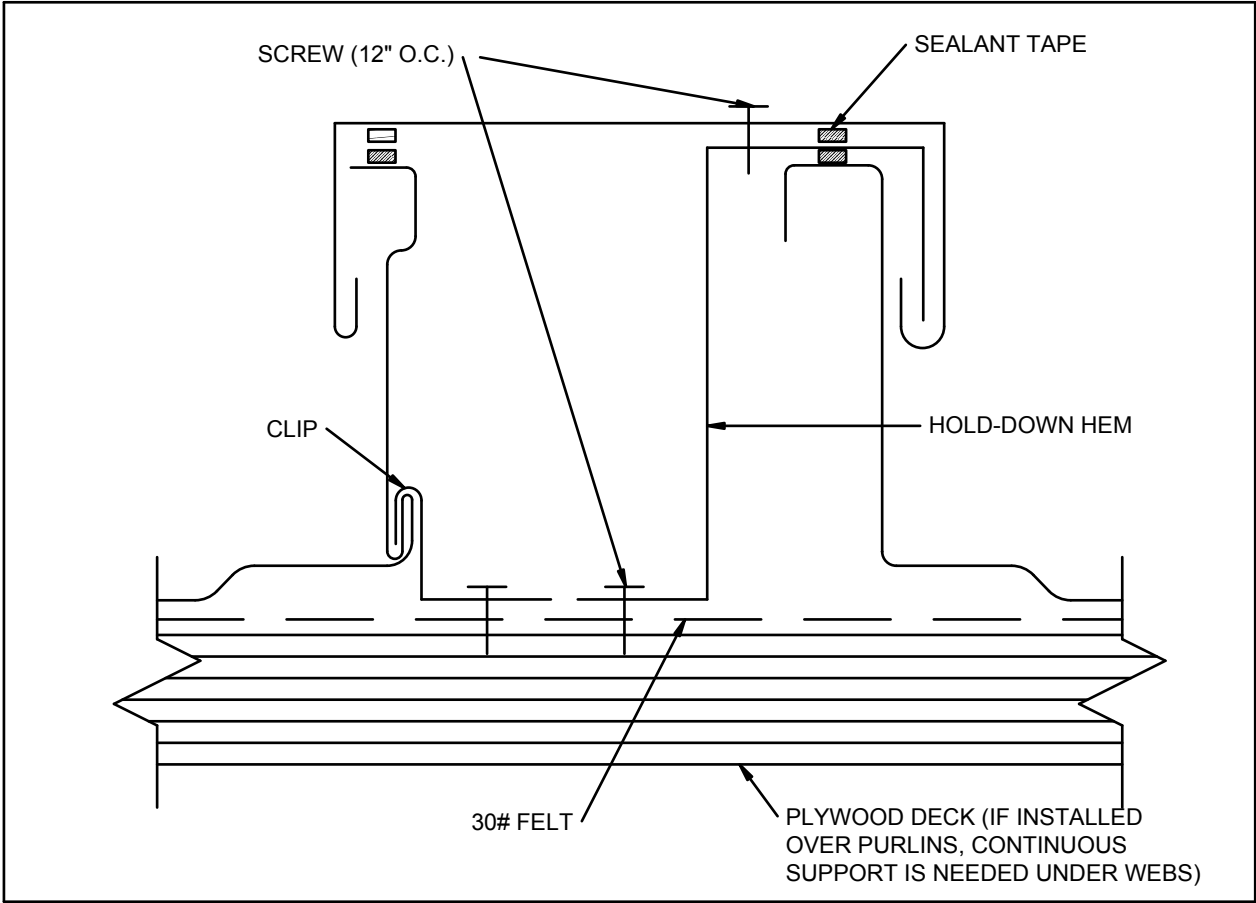

SOFFIT DETAILS

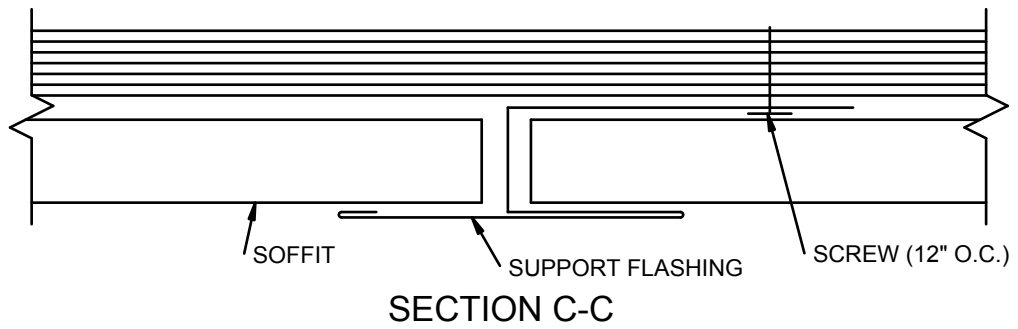
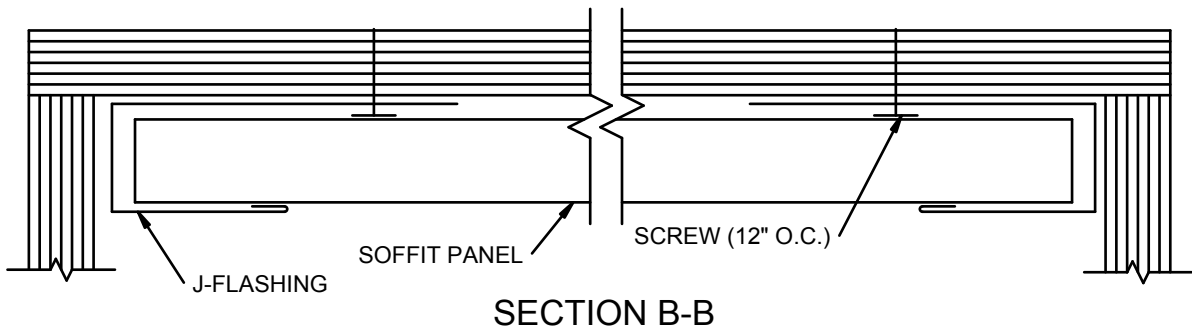
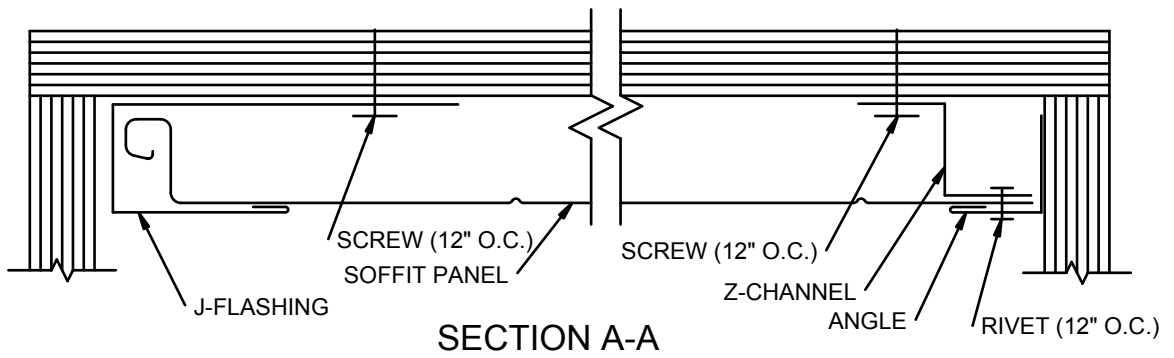
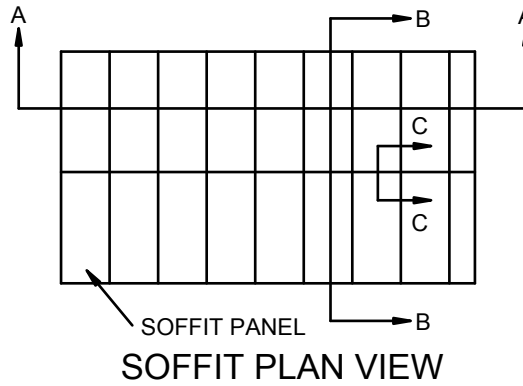

DORMER PEAK

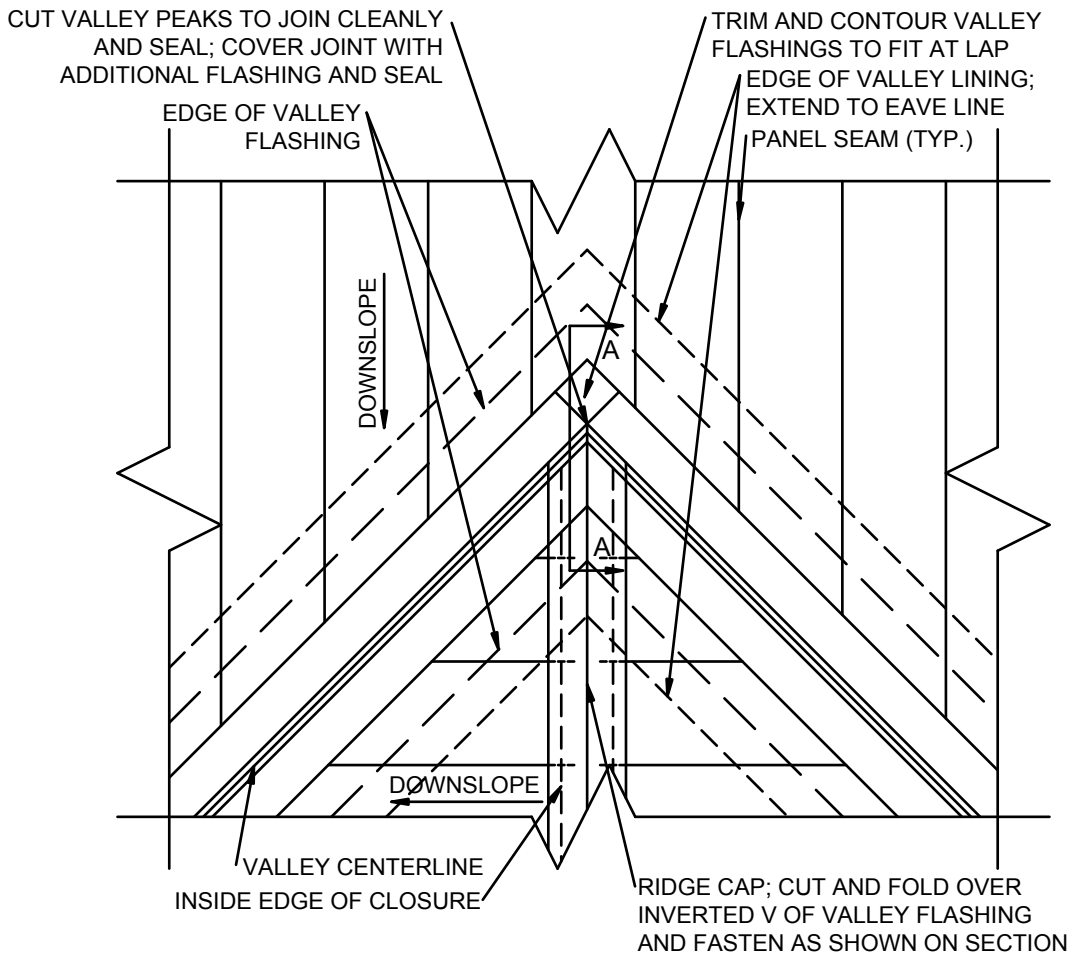

PLAN VIEW OF TOP OF DORMER

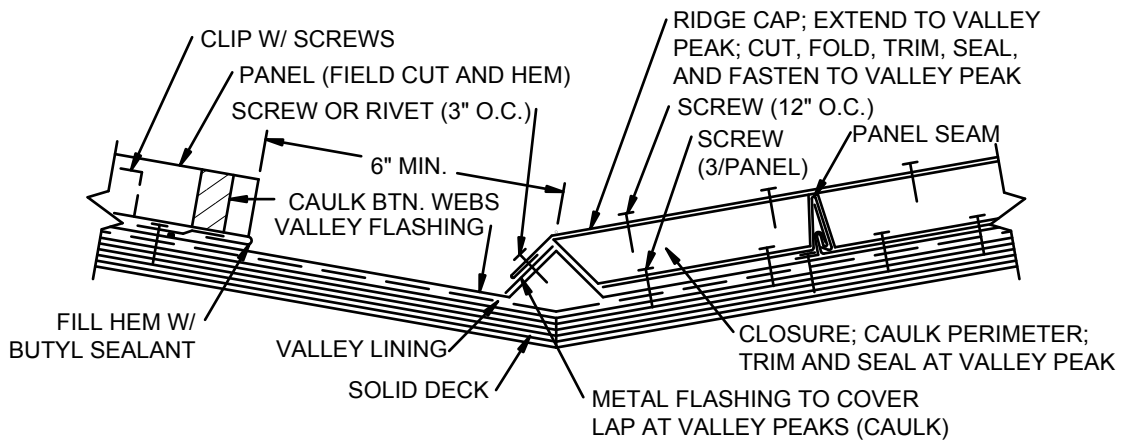

SECTION A-A

DORMER SIDE

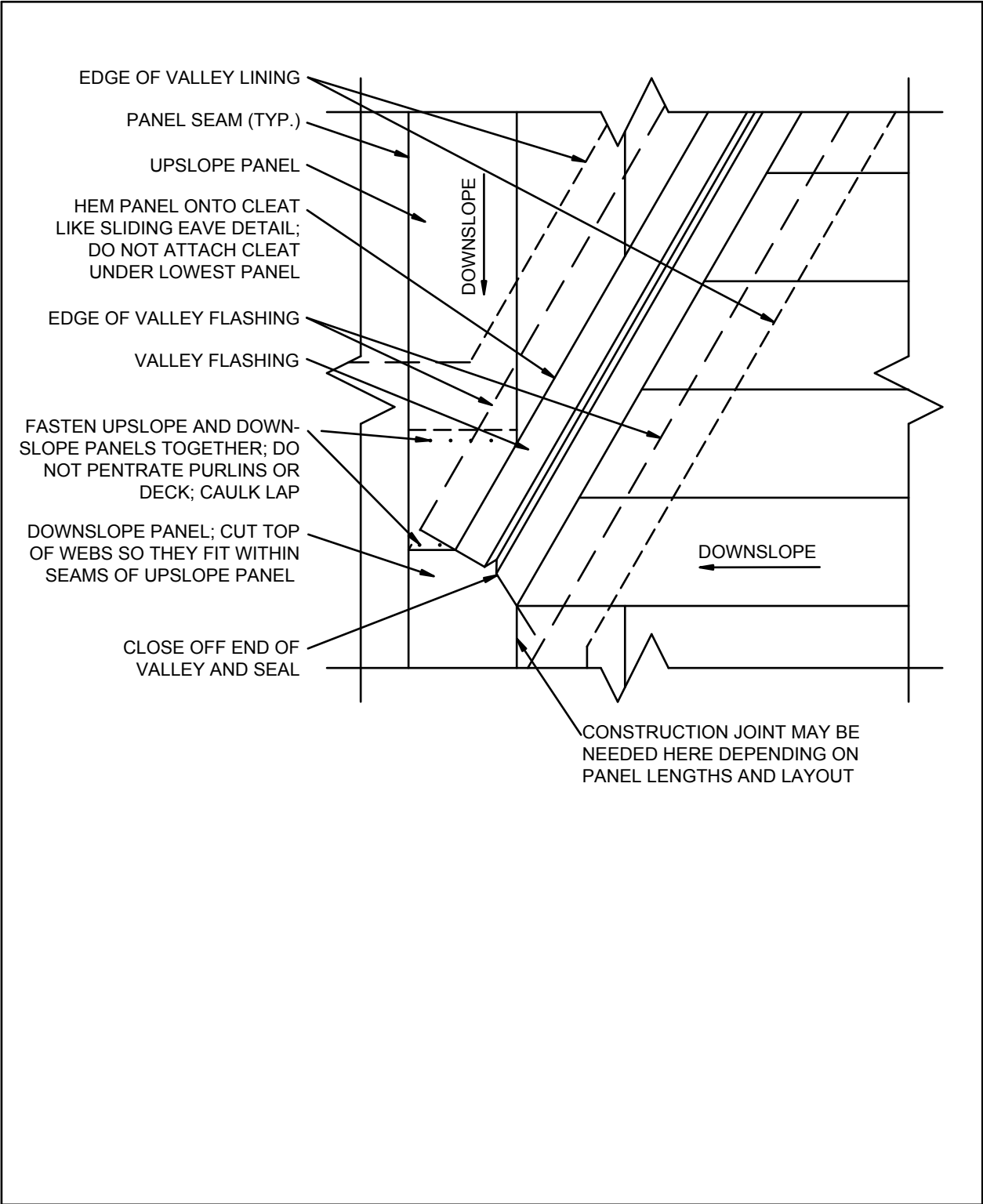

FABRAL®

A FLACK GLOBAL METALS COMPANY

FABRAL.COM

1-800-4FABRAL (432-2725)

Manufacturing Facilities:

Lancaster, PA: (717) 638-2809

Jackson, GA: (770) 230-8093

Ft. Worth, TX: (817) 286-5100

Gridley IL: (309) 280-6205

St. Joseph, MN: (816) 205-8111

Marshfield, WI: (715) 800-6006

Salt Lake City, UT: (385) 243-6333

Spokane, WA: (509) 204-8013

Due to product improvements, changes and other factors, Fabral reserves the right to change or delete information herein without prior notice.