

# FABRAL<sup>®</sup>

METAL WALL AND ROOF SYSTEMS

GRANDRIB 3 PLUS, GRANDRIB 3, TRUSTIRIB, MIGHTI-RIB, PROCLAD, HORIZON SERIES, FABRIB, ENDURACOTE, FABRAL, FABRAL CORE are registered trademarks of OmniMax International, Inc.

UL is the trademark of UL LLC

Galvalume is the trademark of BIEC International Inc.

© **Fabral 2017. All rights reserved.**

**Fabral.com**

Due to Product improvements, changes and other factors, Fabral reserves the right to change or delete information herein without prior notice or obligation to make changes in products previously purchased.

The details and written instructions described in this manual are suggested installation methods to ensure a quality application of our products, and should be considered as a guideline only. FABRAL recognizes that installation techniques can vary based upon builder and geographical preferences, and that there are other acceptable ways to install our products.

Fabral.com

## TABLE OF CONTENTS

Introduction.....	2
Fabral Core .....	3
Installation Guidelines.....	4-5
Recommended Tools and Equipment.....	6
Proper Handling.....	6
Proper Storage.....	6
Estimating and Ordering .....	7-13
Fasteners.....	14
System Components & Accessories .....	14
Flashings & Trims .....	15-16
Trim Details	
Eave.....	17-18
Gables .....	18-19
Sidewall .....	20
Endwall.....	21
Dormer .....	22
Transition.....	22
Gambrel .....	23
Step Down .....	23
Non-Vented Ridge .....	24
Vented Ridge .....	25
Monoslope Ridges .....	26
Valleys .....	27
Pipe Boot Penetration .....	27
Curb .....	28
Skylights.....	29-31
Chimneys.....	29-33
Key Terms.....	34
Paint Systems & Warranty.....	35
Complete Contact Information.....	36
Locations & Service Areas .....	37

## INTRODUCTION

# The Right Tools.

This 1 1/2" SSR Installation Guide is the right tool to have at your fingertips. By knowing you have access to all of the right information, from proper storage and installation instructions to trim and flashing details, you can be confident installing your Fabral materials.

Use this guide, and call us when further support is needed.



## AGRICULTURAL

Fabral is the solution for your agricultural applications. We know that your barns and buildings must stand up to all weather conditions and last through the years.



## LIGHT COMMERCIAL

For your light commercial needs, Fabral offers metal roofing and siding to match the various building types.



## RESIDENTIAL

Homeowners feel proud and confident with Fabral metal roofing for its durability and sophisticated appearance.

# You challenge us. And we like it.

Your vision for a building and what you want to achieve makes us think harder. It'd be easy to say, "That won't work." Instead, we go with "Let's see what we can do." As the leading provider of metal building envelope solutions, we push the envelope.

We like it when you bring us a problem because we know we'll find the solution. We have the products, the manufacturing and the know-how. We offer everything you need for the total building envelope solution. At our core, we relish a challenge.

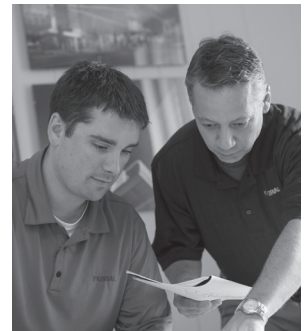
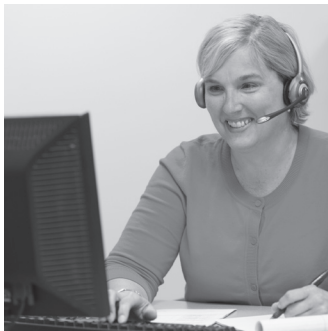

SYSTEM  
SUPPORT

CUSTOMER CARE

EDUCATION

PROJECT CONSULTING

TECHNICAL SUPPORT

# INSTALLATION GUIDELINES

The information in this booklet has been prepared to assist the designer and installer with the proper application of FABRAL's 1-1/2" SSR roof system. Since each project is unique, the information is intended to be used as a guideline and in no way insures proper application of the 1-1/2" SSR.

## Panel Specs:

Substrate: Acrylic Coated Galvalume® Steel  
Available in 9 Paint Colors: White, Caribbean Blue, Brick Red, Classic Burgundy, Hickory Moss, Evergreen, Charcoal Gray, Antique Bronze, and True Black  
Weight = 130 lbs/sq  
Minimum Slope: 1:12  
Lengths: Minimum 7'                      Maximum 47'6"  
Panel does NOT endlap — contact Fabral about long length roof runs

## PRE-Installation:

Note 1: Lead and copper flashings from existing chimneys, skylights, endwalls and other areas must be removed prior to installation of the new galvanized 1-1/2" SSR. Lead and copper corrosive when used with galvanized steel.

Note 2: Proper design for attic ventilation for the particular building is the responsibility of the designer, engineer or homeowner, and should comply with local codes. Ventilation design is not the responsibility of FABRAL. With any metal roof system vented soffits, gable vents, and ridge vents can be used as part of the overall design.

Note 3: All panels are factory caulked with a 1/8" bead of butyl sealant in the overlapping rib. This caulking may not be visible within 6" of the end of the panels, but can be found inside the overlap rib. Smearred caulking can be removed from the roof with mineral spirits and a soft cloth.

## Installation:

1. Check the support system or roof deck to be sure all supports are installed straight, square and inplane. Solid decking is recommended to help reduce oil canning and for all residential applications. Typically a minimum 1/2" plywood or 2x4 furring is used as support for the 1-1/2" SSR metal roof system. 9/16 OSB or wafer board decking can be used with reduced clip spacing. (Refer to load tables on page 5).

2. Install specified underlayment (such as a minimum 30# felt, Pro-Master UDL, and "Ice and Water Shield").
  3. Install the trim as shown in detail.
  4. Notch eave of panel 1" and bend the hem under by using the hem-bending tool. Snip off underlap rib flush with the hem edge of the panel pan. Trim and fold overlap rib of panel to provide a clean closed panel rib appearance. Use One-Part Polyurethane sealant on this portion of the rib to provide a weather tight seal. REMOVE the clear strippable film on the painted side of the overlap rib before installing!
  5. Starting at the gable end, install the first 1-1/2" SSR panel parallel to the gable with the overlap edge along the gable. Apply tape caulk and place sliding gable cleat over overlap edge and screw down the gable cleat.
  6. Install the 1-1/2" SSR clips at the required spacing along the lengths of the panel, using two (2) #10x1" Pancake woodfast screws in each clip. Clips should be spaced a maximum of 24" c/c apart, and may require closer spacing over solid decking. (Refer to load table on page 5).
  7. Position the next panel over the under-lap leg. Engage 6" to 12" of the overlapping rib and slide the panel open hem over the nose of the eave flashing. Starting at the eave, apply pressure to the overlap rib until it locks into position. Apply continuous pressure on overlap rib so as to snap it down over the underlap rib. Do this the entire slope along the length of the panel.
- NOTE:** On steep pitches it may be necessary to put 1 or 2 fasteners through the pan of the panel, at the top of the panel (ridge/hip/endwall) to prevent the panels from sliding down the roof. Make sure these fasteners are above the area where the top metal Z closure will be placed so they are hidden when finished.
8. Slide panel open hem over the nose of the eave flashing and continue the above procedure across length of the roof.
  9. To finish the ridge, first install the top metal Z closures. All closures should be set in sealant, on the pan of the panel to insure proper weather tightness. (Once closures are set, install 3 #14x1" MP screws to fasten through the closure and through the panel,

# INSTALLATION GUIDELINES

into the decking or purlin. This is critical; these 5 #14x1" MP screws hold the panel in place from sliding off of the roof.) One-Part Polyurethane sealants must be applied behind all closures, up the rib edges, and butyl sealant applied on top of the metal closures, prior to installing the ridge cap flashing or Coravent ridge vent. If installing snowguards on the panels extra ridge screws must be installed.

10. Follow similar procedures for completing gable, hip and valley conditions.
11. Prior to the end of each workday, all panels and trim should be adequately fastened to prevent any damage due to wind uplift or gravity. See #7 "Note" about securing panel ends at the ridge/hip/endwall.
12. All flashings should be lapped 4" to 6", sealed with sealant, and stitched together with screws 4" o/c. Flashings should be held in place with continuous cleats or fasteners 16" o/c.

**NOTE:** Oil-canning can be induced by a variety of conditions, including construction misalignments and is NOT cause for rejection of material. If oil canning occurs, the installation of an ethofoam backer rod under the center of the panels can significantly improve the appearance. **INSTALLATION TIP:** Even pressure should be applied to the overlap rib to provide a "zip-up" type application when snapping the panels together. This assures that the panel will not kink along the rib as the entire length is being snapped together. Caulking in the rib will not allow moving the panel once it is snapped in place. The hem at the eave should be secured in place prior to locking the panels together.

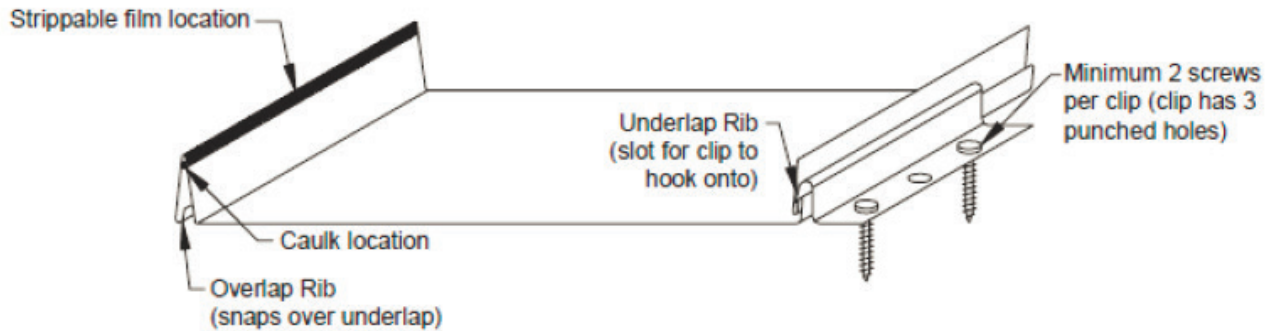

Fabral recommends spacing the clips 24" apart (maximum) or closer (depending on wind load or bearing design requirements)

ALLOWABLE UPLIFT (PSF) - 24 GA STEEL  
Purlin or Nailer Spacing (inches) (L)

ALLOWABLE LIVE LOAD (PSF) - 24 GA STEEL  
Purlin or Nailer Spacing (inches)

Substrate	Spans		9"	12"	15"	18"	21"	24"
2x4 SPF	3+	Load (lb/sq ft)	206.25	154.69	123.75	103.13	88.39	77.34
1/2" Plywood	3+	Load (lb/sq ft)	61.60	46.20	36.96	30.80	26.40	23.10
9/16" OSB	3+	Load (lb/sq ft)	52.00	39.00	31.20	26.00	22.29	NR
*UL90 rated over 1/2" Plywood								

Spans		12"	18"	24"
3+	Load (lb/sq ft)	466	207	116



# INSTALLATION GUIDELINES

## RECOMMENDED TOOLS & EQUIPMENT

1. Screw Guns
2. 1/4" hex driver
3. 5/16" hex driver
4. #2 Combination Squallt/Phillips magnetic drive
5. Extension cords or battery packs and chargers
6. Aviation Tin snips (yellow handle- straight cut)
7. Nibbler - optional
8. Press brake - optional
9. Duck bill metal benders
10. 1-1/2" SSR Bending Tool
11. Hammer and roofing nails
12. Caulk gun
13. Rubber mallet
14. Chalk line
15. Tape measure

## PROPER STORAGE

When moisture remains in contact with Galvanized panels in the absence of freely circulating air, white, black or dark gray corrosion products begin to form. Moisture can get between stacked panels either through capillary action or atmospheric humidity. If moisture becomes entrapped between the sheets, this condition can result in water stains or white rust, which can affect the service life of the metal and will detract from its appearance. If the metal panels will not be installed immediately, store them in a well-ventilated, dry area to minimize exposure to moisture. Use wood blocking to elevate the panels at least 1 foot off the ground in an inclined position. This will allow circulation of air between the panels and provide positive drainage. If outdoor storage cannot be avoided, protect the metal with a breathable canvas or waterproof paper cover. Leave the bottom of the cover loose to allow air circulation between the sheets. Do not use plastic, which causes sweating or condensation.

## PROPER HANDLING

Panel crates must be lifted at bundle block locations. Center the load on lifting device and do NOT unload in jerking or bouncing fashion. This may cause package to slide on forks and damage panels.

- Do NOT lift material with ropes or wires.
- Do NOT lift panels greater than 25" long without a spreader bar.
- Do NOT lift panels from ends while flat. Lift panels on edge when moving individual panels or when moving onto the roof.
- Panels should be lifted and carried on edge with one worker for each 10'-0" of panel.

Carry on edge  
as shown

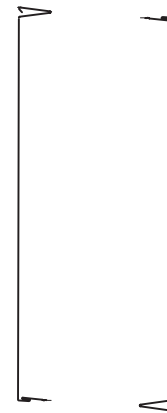

NOTE: Before installation, remove the clear strippable film that is applied to the painted side of the overlap leg. This film is for transportation protection only, and if left on, will be baked onto the paint finish by the sun.

## 1 1/2" SSR Panel Profile (varies slightly by region)

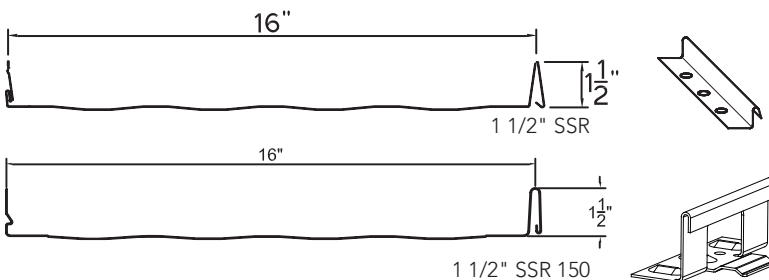

Factory Applied Sealant  
Shadow Lines Standard; Flat Pan & Stiffening Ribs Available

**STEP 1**

A. Sketch a birds-eye view of the roof and label each section (see example below.)

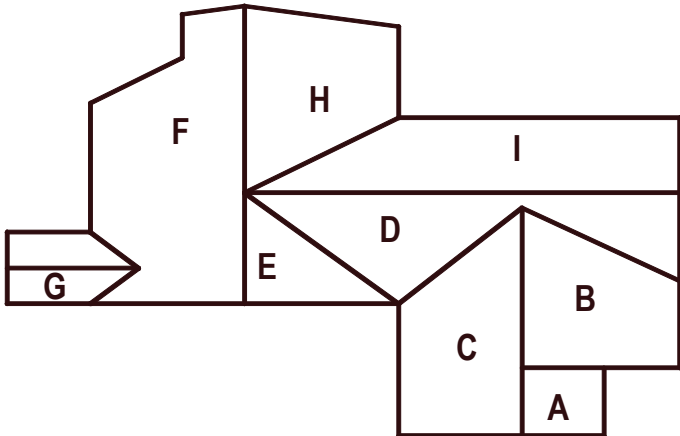

B. Sketch a diagram of each roof section. Show all measurements (see example below.) It is important to measure the exact center of the ridge to the eave edge. Do not add extra length for overhang.

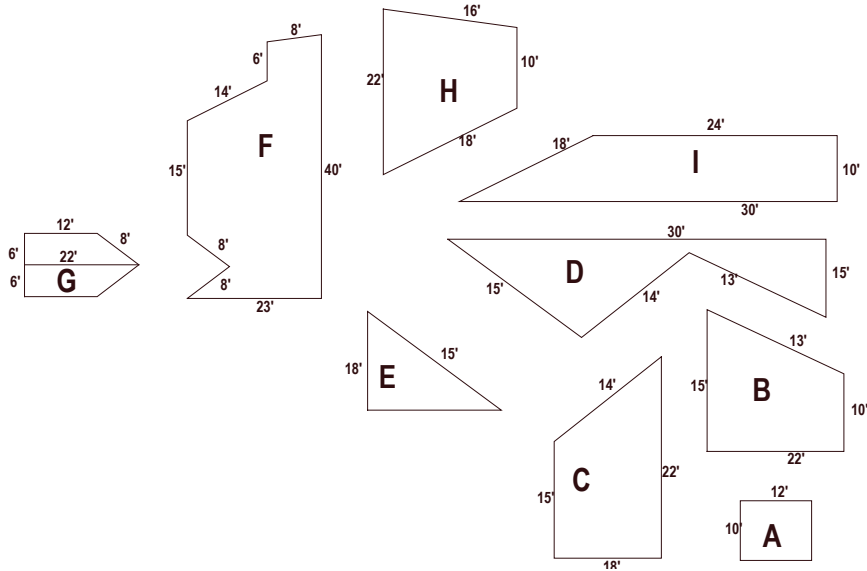

Additional Information Required: Roof Pitch, Skylights (Location & Size), Chimneys (Location & Size), and Size and Number of Pipe Penetrations.

Additional Identification: Ridge, Hips, Valleys, Gables, Etc.

# ESTIMATING & ORDERING

## STEP 2

With the information from the diagram you completed in Step 1, you are now ready to complete your roofing panel cut list. Since each panel is 16" wide, only measurement you need is the distance from the eave to the ridge. You can then determine the number of panels needed to cover the length from gable to gable. (See example Diagram A below.)

### DIAGRAM A

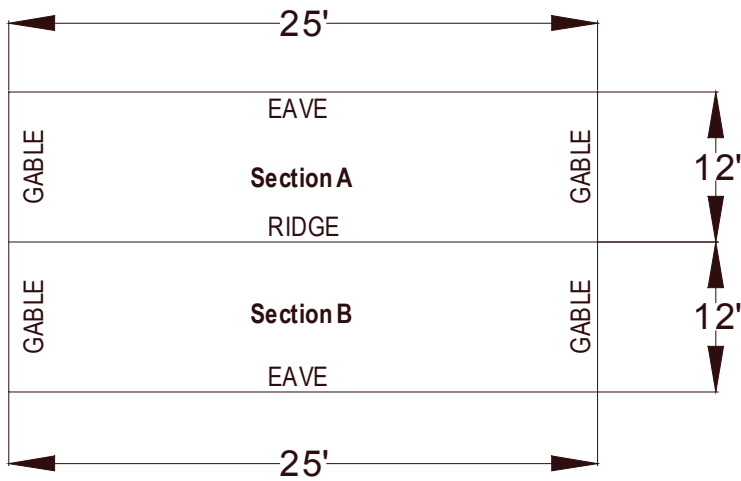

The length from the eave to the ridge is 12'. The length of the ridge is 25'; therefore, the number of panels to complete one side of the house is  $25' \div 1.33'(16'') = 19$  pcs. Your materials list should look like Sample B.

### SAMPLE B

Section A - 19 pcs. X 12'

Now look at your roof diagram and figure out your next section of roof. Refer back to Diagram A. Section B of this sample roof is the same as Section A. Your materials list should now look like Sample C below.

### SAMPLE C

Section A—19 pcs. X 12'

Section B—19 pcs. X 12'

If your home has hips or valleys, refer to Diagram 1A on page 9.

**STEP 2 (CONT.)**

**DIAGRAM 1A**

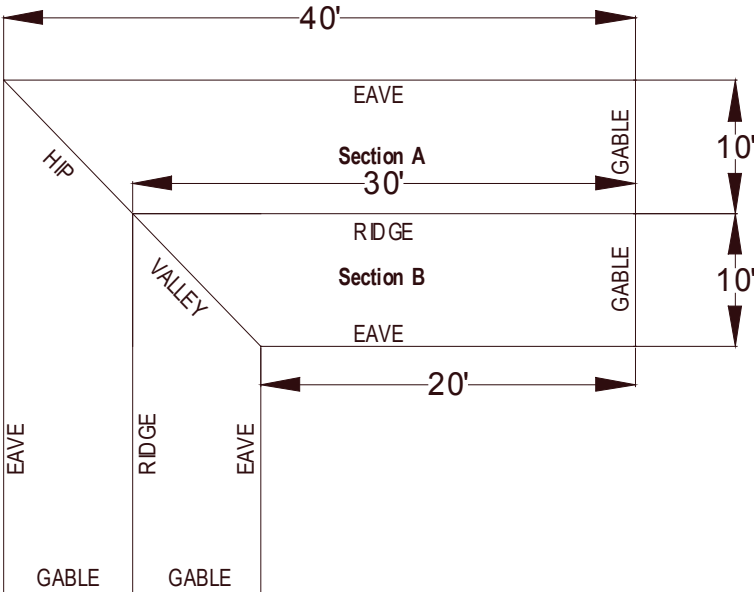

Start with section A. The eave length is 40' and the ridge length is 30', with a difference of 10'. You will need 23 pcs. X 10' to reach the area where the hip starts. Remember that you have 10' remaining to cover the area, or 8 more panels. Determine the length of each panel going into the valley by calculating the roof's pitch. Pitch is how much rise your roof has in inches for every foot of horizontal run. Use the Hip and Valley Chart below to ensure we order the correct panel length for hips and valleys, keeping in mind that panels are cut to the nearest full inch. For example, Diagram 1A is a 4/12 pitch (4/12p). According to the chart below, each panel will be 17" shorter. Since you are measuring from the longest point of the angle, your first piece will be the same length as the full eave to ridge measurement and each piece after will be 17" shorter. (Your list of Section A should look like Sample D on page 9.)

**HIP & VALLEY CHART**

When determining the panel length needed for a hip or valley, the panel will either be shorter or longer as you go up or down the hip or valley. The chart below shows you the amount to add or subtract from each panel according to the pitch of your roof.

3/12p = 16 1/2"	6/12p = 18"	9/12p = 20"
4/12p = 17"	7/12p = 18 1/2"	10/12p = 20 3/4"
5/12p = 17 1/2"	8/12p = 19"	11/12p = 21 3/4"
		12/12p = 22 3/4"

Example: 3/12 pitch = 16 1/2" panel length  
 Note: When determining panel length, always round up to the next full inch.

# ESTIMATING & ORDERING

Customer: \_\_\_\_\_ PO#: \_\_\_\_\_  
 Job Name: \_\_\_\_\_

Panels cover 1.33 ft (16 inches) width

Eave to Ridge distance in flat X Slope factor = \_\_\_\_\_ panel length

or Actual on-slope measurement from eave to ridge = \_\_\_\_\_ panel length

\*Remember to figure in eave and gable overhangs when calculating lengths and widths

(Panel run allows for 1" Eave Hem, 1" overhang and 2" to 3" gap at Ridge)

(For Endwall panels, add 1" to the eave to endwall base measurement)

Panel Listing			
Color _____	_____ pcs @ _____ ft- _____ in.	_____ pcs @ _____ ft- _____ in.	_____ pcs @ _____ ft- _____ in.
(Choices: White, Evergreen,	_____ pcs @ _____ ft- _____ in.	_____ pcs @ _____ ft- _____ in.	_____ pcs @ _____ ft- _____ in.
Charcoal, Caribbean Blue,	_____ pcs @ _____ ft- _____ in.	_____ pcs @ _____ ft- _____ in.	_____ pcs @ _____ ft- _____ in.
Red, Hickory Moss, Classic	_____ pcs @ _____ ft- _____ in.	_____ pcs @ _____ ft- _____ in.	_____ pcs @ _____ ft- _____ in.
Burgundy, Antique Bronze,	_____ pcs @ _____ ft- _____ in.	_____ pcs @ _____ ft- _____ in.	_____ pcs @ _____ ft- _____ in.
Acrylic coated Galvalume)	_____ pcs @ _____ ft- _____ in.	_____ pcs @ _____ ft- _____ in.	_____ pcs @ _____ ft- _____ in.
Factory Caulked	_____ pcs @ _____ ft- _____ in.	_____ pcs @ _____ ft- _____ in.	_____ pcs @ _____ ft- _____ in.

Total Lineal Feet of Panels = \_\_\_\_\_

Total Lineal Feet \_\_\_\_\_ x 0.0134 = \_\_\_\_\_ sqs. (Pricing will be based on actual squares shipped)

Squares \_\_\_\_\_ x 38 clips/sq. = \_\_\_\_\_ pcs. 1-1/2" SSR Clips (clips included in panel price)

(Note: 38 clips per 100 square feet of panel is based on 24" clip spacing. Closer clip spacing requires purchasing additional clips)

Number of Clips \_\_\_\_\_ x 2 screws/clip = \_\_\_\_\_ pcs. Clip Screws #10x1" Pancake Woodgrip

(Transfer to page 2 - #10x1" Pancake Head WG)

Directions: Fill in lineal feet of the various roof conditions. Utilize these numbers in the appropriate spaces below to calculate the total number of pieces needed of each item. If a space doesn't have a number or a zero, it doesn't need to be calculated. Round all piece counts up to the next highest number. Increase all fastener quantities by 10% for drop/loss. Additional accessories are required for endwall, sidewall or transition details.

\* Round all fastener quantities to nearest 100 pcs.

Lineal Feet of Conditions	Pitch	Slope Factor
	1-12	1.003
	2-12	1.014
Eave _____ Valley _____	3-12	1.031
Ridge _____ Hip _____	4-12	1.054
Vented Ridge _____ Transition _____	5-12	1.083
Gable _____ Gambrel _____	6-12	1.120
Sidewall _____ Roof Pitch = _____" in 12"	8-12	1.202
Endwall _____	10-12	1.302
	12-12	1.414



# NEW ROOF APPLICATION

1. Make sure there are no nails or other objects protruding from the substrate that might puncture the underlayment or damage the roof panels. Clean all debris from the deck.

2. Check all details for possible roof penetrations which must be added to the deck prior to roof panel installation (vented ridge for example).

3. Begin at the eave at the gable end and roll out the underlayment horizontally (parallel to the eave). Allow each consecutive course to overlap the previous one by 4-6". Overlap the end a minimum of 6" when starting a new roll of underlayment. Areas of underlayment that have been torn or cut should be replaced or repaired prior to installation of the metal roof. (See Illustration #1 below) Ice & Water shield should be used in cold climates starting at the eave and extending at least 24" past exterior walls.

4. Place an alignment line along the gable end where the first roof panel will be installed. THIS LINE MUST BE LOCATED 1/2" IN FROM THE GABLE EDGE OF THE ROOF DECK AND SQUARE WITH THE EAVE LINE. Various methods exist for ensuring that the line is square. Call your nearest FABRAL representative if you need assistance. (See Illustration #2)

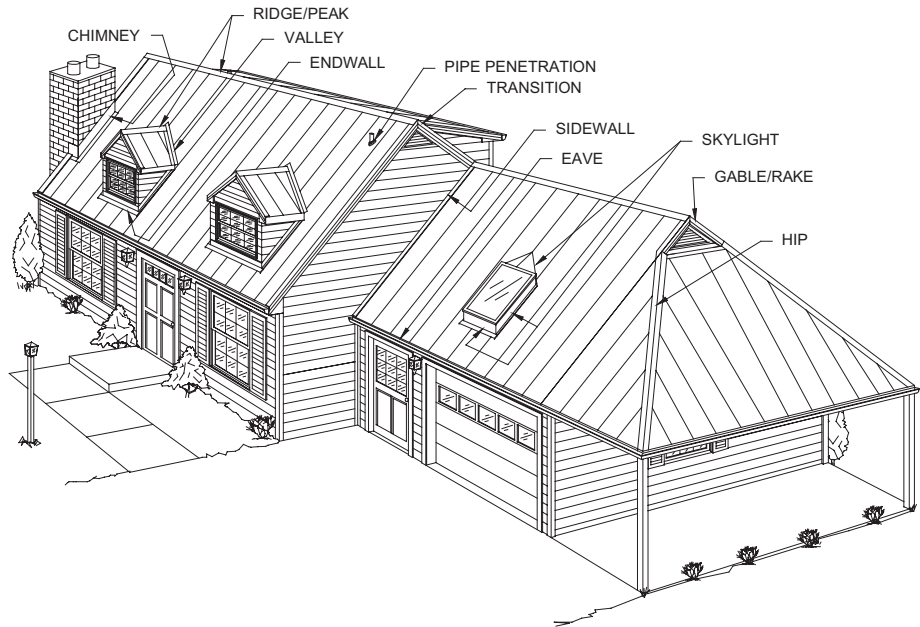

**ILLUSTRATION #1**

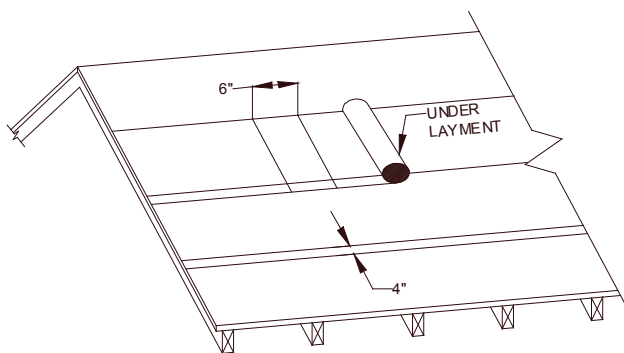

**ILLUSTRATION #2**

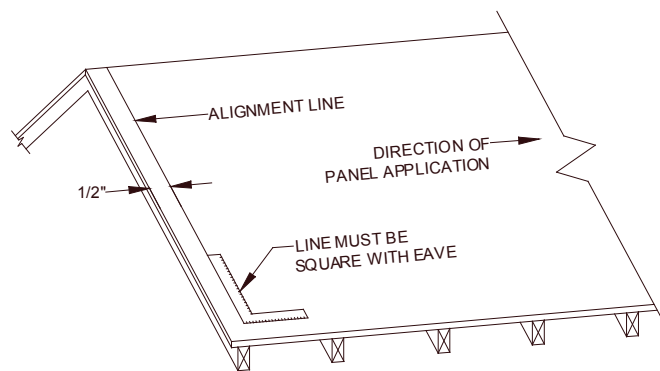

## EXISTING ROOF APPLICATION

In many cases, **FABRAL's** 1 1/2" SSR Panels can be installed over existing roofing.

Some jurisdictions will allow retrofit over certain types of roofing without tear-off of the old roofing. For best results, always use furring strips and 30 lb. felt paper over old shingles. Furring strips can be installed 24" o.c. with 1 1/2" SSR to provide adequate panel support and wall capability. Check with your local codes or building department for the specific requirements in your area.

If the roof is to be stripped down to the existing decking, follow the procedures for new roofs on page 13. Be sure to check the existing roof and repair any damaged areas prior to installation of the new roof system.

The following steps should be taken when installing 1 1/2" SSR roof panels over existing roofing.

- Inspect the roof for damage and make the necessary repairs.
- Secure any warped or loose roofing material.
- Make sure there are no nails or other objects protruding from the roof that might puncture the new underlayment or damage the new roof panels.
- Remove all moss and other debris from the roof.
- Cut off any overhanging roofing flush with the roof deck, and remove all hip and ridge caps.
- Follow the directions on page 13, #2 through #4, on roof preparation.

Note: For best results, 1 1/2" SSR Roofing requires a relatively smooth and flat substrate. Application over rough and/or uneven surfaces is not recommended, as this will cause oil-canning.

### PANEL INSTALLATION

Note: Prior to panel installation, determine which items need to be installed prior to panels (such as vent screen, eave, valley, swept wing, etc.)

1. Install eave trim.
2. Working off the eave edge, establish a straight line up the gable edge from which you are starting. This will insure that the first panel laid will be straight and square with the eave. (See Illustration #2 – page 13)
3. Align first panel 1 1/8" to 1 1/4" from the gable edge. Attach the gable cleat flush along the gable edge with screws every 16" o.c. Secure the panel to the roof deck using a panel clip with 2 fasteners in each clip. (See page 5 for clips spacing recommendation.)
4. Install the gable trim and face screw it to fascia board (see page 21). This fully secures the first panel to the roof.
5. Position the second panel (overlap edge on top of the underlap edge of first panel) assuring that the eave edge is in position (1" overhang). Secure the second panel to the first panel by applying slight pressure on the overlap seam (or use rubber mallet) working from the eave toward the ridge. The overlap edge of the panel contains factory-applied sealant to ensure weathertightness. Be sure that you achieve a positive engagement between panels. Fasten the panel to the roof as in step #3 above.
6. Each consecutive panel will be applied as in step #3 and #5 above.



# FASTENERS Recommended fasteners for the proper installation of 1 1/2" SSR panels

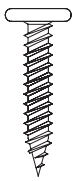

- #10-1 Pancake Head Screw**
- Use for clip attachments
  - Available in 1"
  - Plain
  - 250/bag



- #14-10 WoodTite**
- Use to fasten metal to plywood or OSB
  - Use for trim attachment
  - Available in 1", 1 1/2", and 2"
  - 5/16" hex head, EPDM/metal washer
  - Oxyseal Long-Life Coating
  - Plain or Painted
  - 250/bag



- #10 woodtite**
- Use with dimensional lumber
  - Available in 1", 1 1/2", 2", 2 1/2" and 3"
  - 1/4" hex head, EPDM/metal washer
  - Oxyseal Long-Life Coating
  - Plain or Painted
  - 250/bag

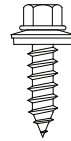

- #12 x 3/4" Stitch Screw**
- Used for attachment of trim to top of seam for screw flange panels
  - Use with STEEL panels
  - Used to stitch sidelaps for exposed fastener panels
  - Used for miscellaneous metal to metal attachments
  - 1/4" hex head, EPDM/metal washer
  - Plain or Painted
  - 250/bag



- #43 Pop Rivet**
- Use for attaching trim to closures
  - Plain or Painted
  - 250/bag

## Proper Installation of Gasketed Fasteners

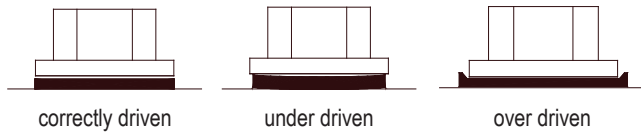

correctly driven

under driven

over driven

## SYSTEM COMPONENTS & ACCESSORIES

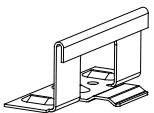

1 1/2" SSR 150

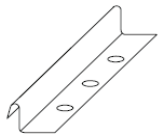

1 1/2" SSR

**CLIP**

2 Pancake Head Screws per Clip

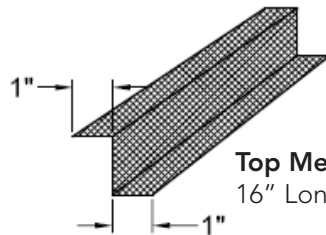

**Top Metal Z Closure**  
16" Long

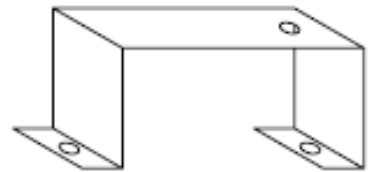

**Ridge Cap Anchor Clip**



14

**Pipe Boot**



**Coravent V-400 Ridge Vent**

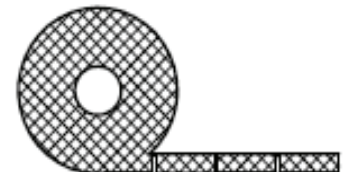

**Profile Vent**

# STANDARD 1 1/2" SSR FLASHINGS & TRIMS

All flashing is 10' 6" in length & available in steel.

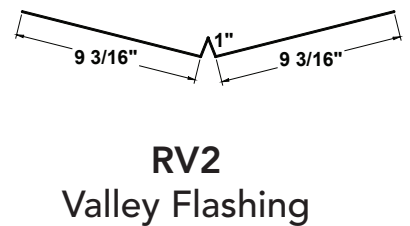
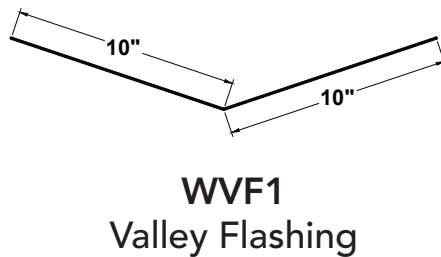
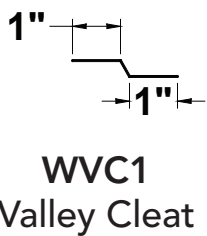
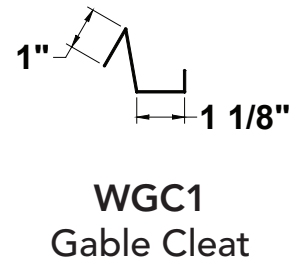
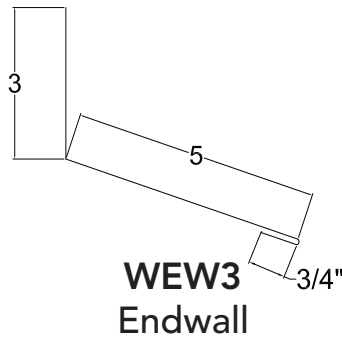
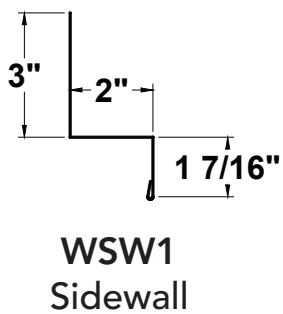
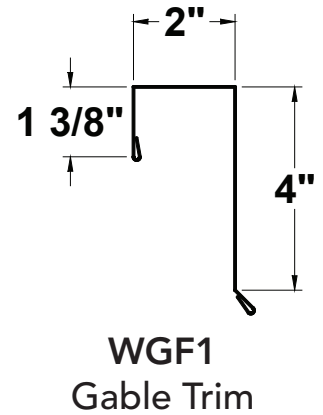
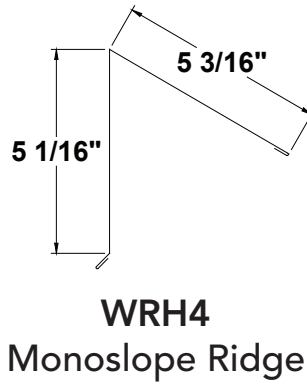
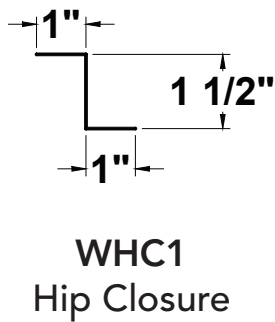
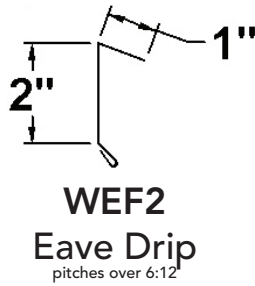
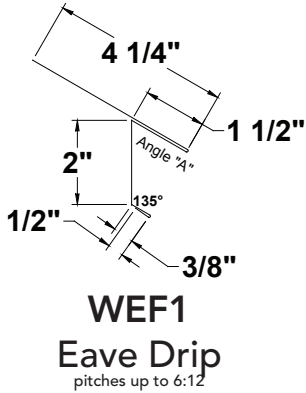

# POST FRAME FLASHINGS & TRIMS

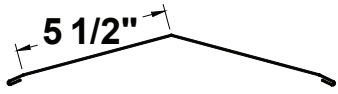

**RR1**  
Ridge

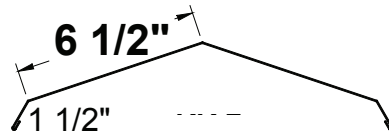

**RR2**  
Ridge

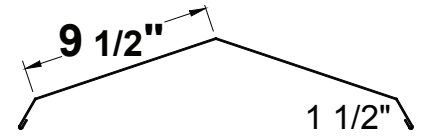

**RR3**  
Ridge

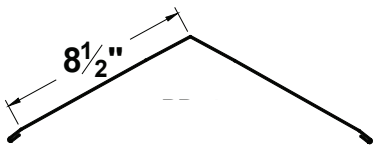

**RR4**  
Ridge

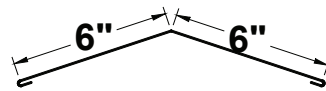

**WRH1**  
Ridge/Hip

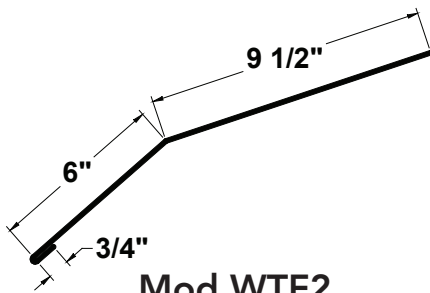
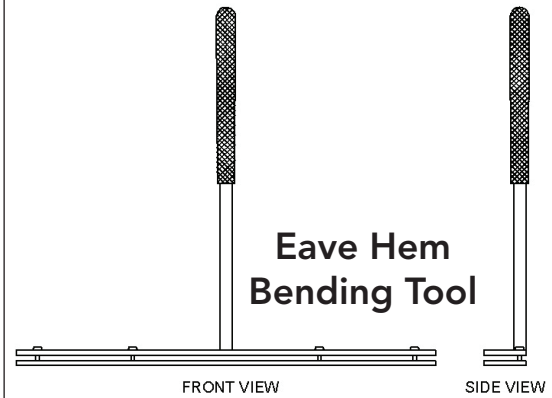

**Mod WTF2**  
Gambrel

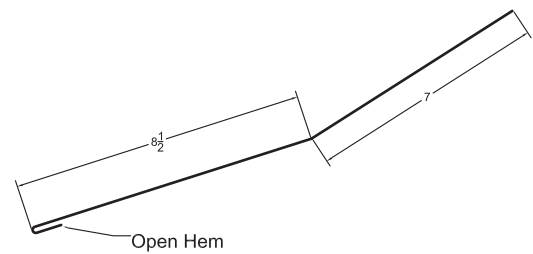

**WTF1**  
Transition

# STANDARD 1 1/2" SSR TRIM DETAILS

## STEP 1

### TWO-PIECE EAVE TRIM

(Use when roof pitch is greater than 6:12)

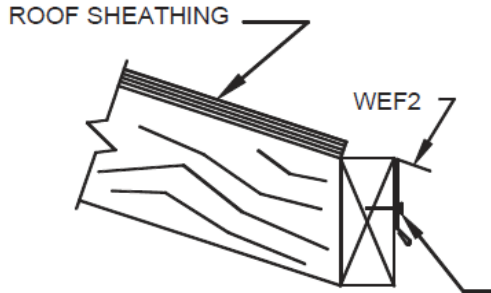

1. Line WEF2 or WEF1 top in line with plywood/purlin.
2. Screw at 12" o.c. across face of trim

#14 x 1" PAINTED

### ONE-PIECE EAVE TRIM

(Use with roof pitches up to 6:12)

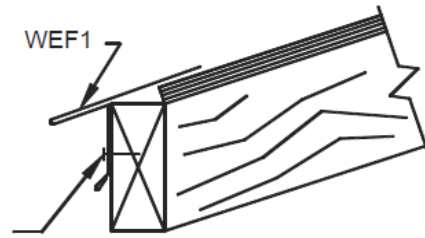

## STEP 2

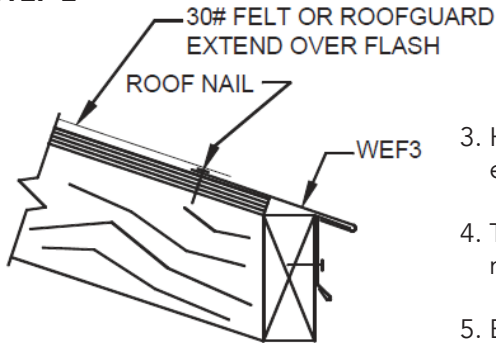

3. Hook WEF3 over hem entire length.
4. Tack in place with roofing nail.
5. Extend felt over eave trim.

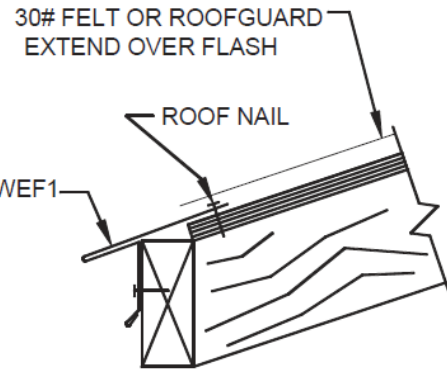

## STEP 3

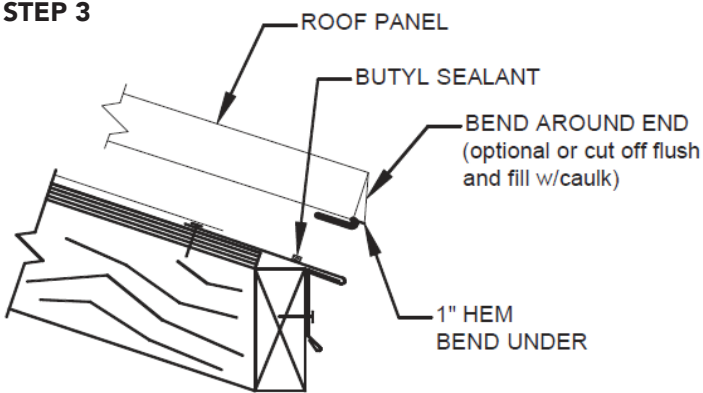

6. Mark 1" in pan of panel and cut beside each rib with a tin snips.
7. Use bending tool to bend hem under the panel.
8. Cut underlap leg off completely for 1"
9. Cut overlap leg as shown on angle Cut to produce a triangular piece to fold, closing the open rib.

## STEP 4

10. Caulk with One-Part Polyurethane up underlap leg.
11. Slide panel over eave hem, tight (in cold weather) or with gap (in warm weather). Snap panels together by applying pressure to the panel rib. Start at the eave and work toward the ridge.
12. A single #14x1" MP fastener can be used near the ridge to hold the panel in place. (This fastener must be installed above the location where the Z closure will be located, not to interfere with the closure.)
13. Panel clips can now be installed on this panel using 2 #10x1" Pancake head screws. Place the first clip near the edge of the substrate as shown in detail.

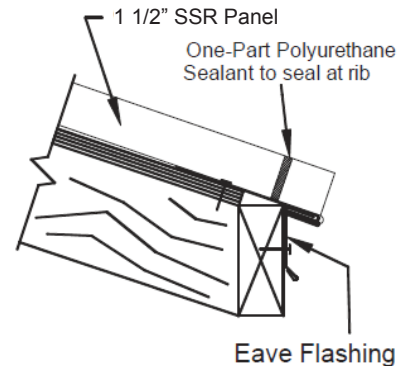

# 1 1/2" SSR TRIM DETAILS

## EAVE

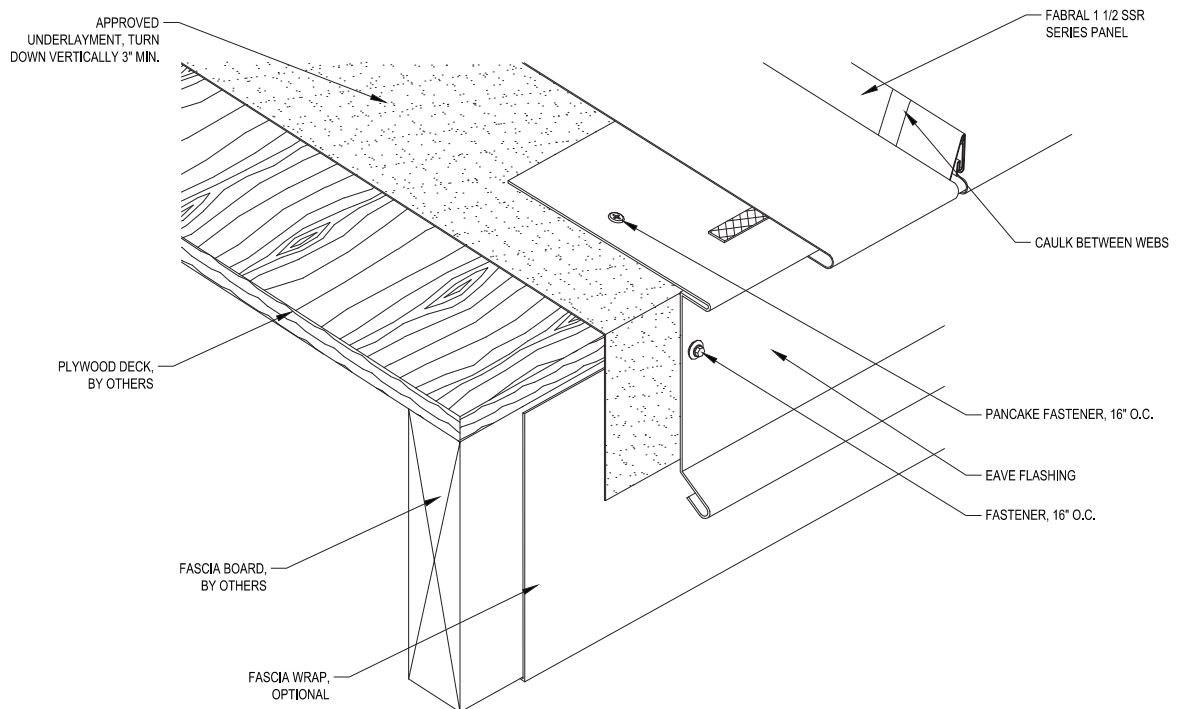

## GABLE

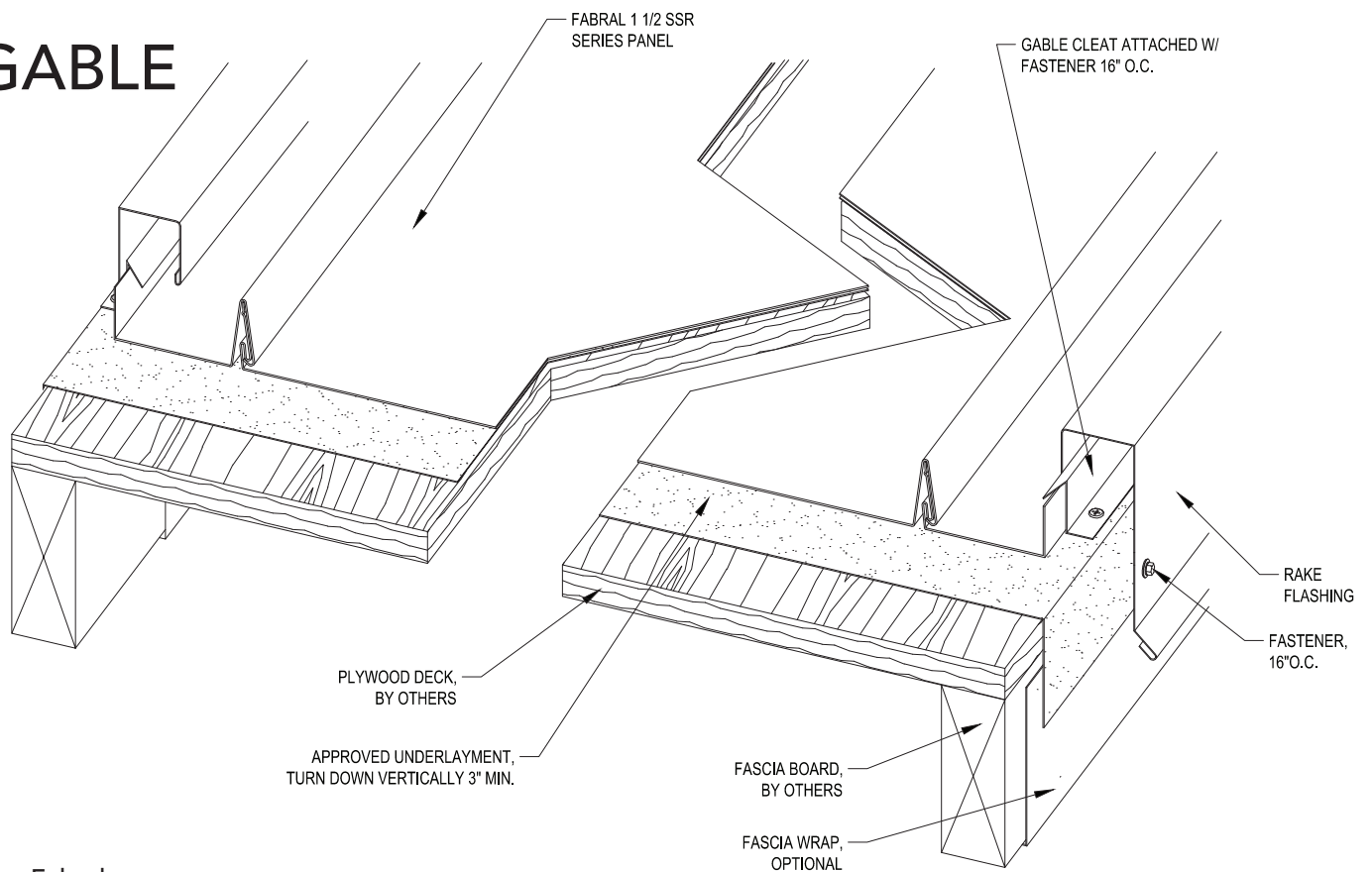

# FLYING GABLE

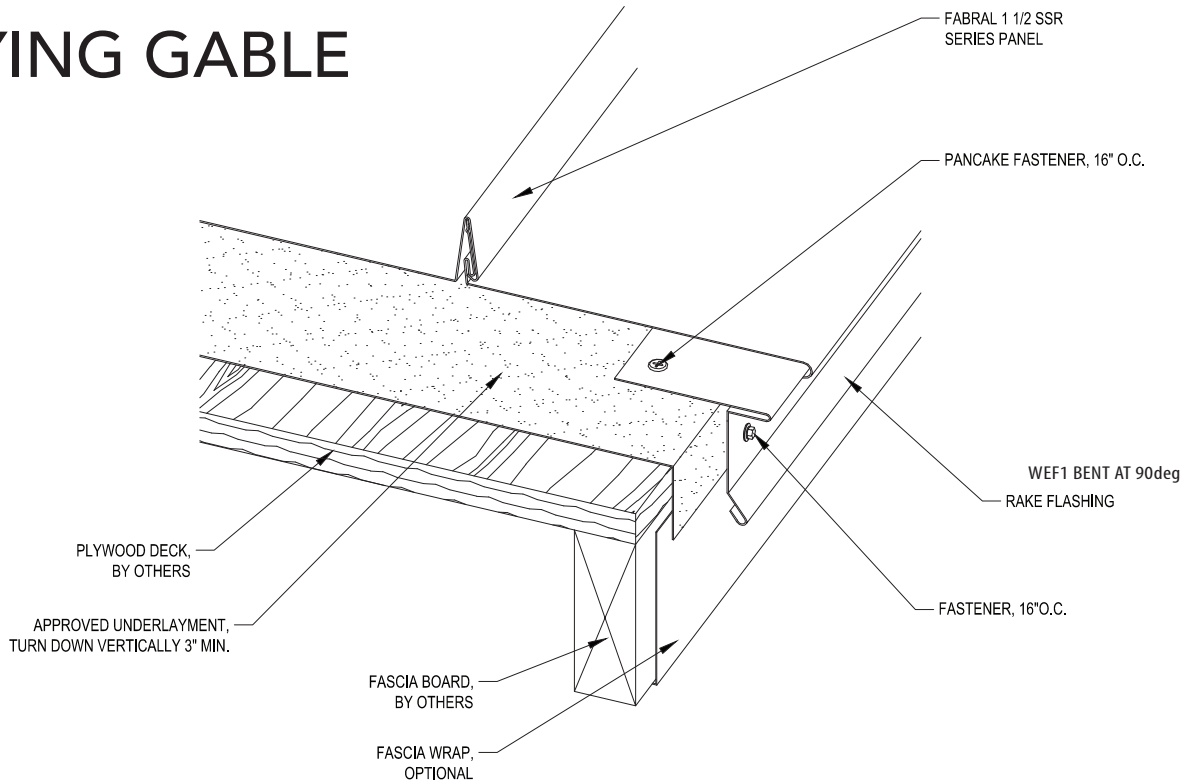

# FINISHING THE GABLE

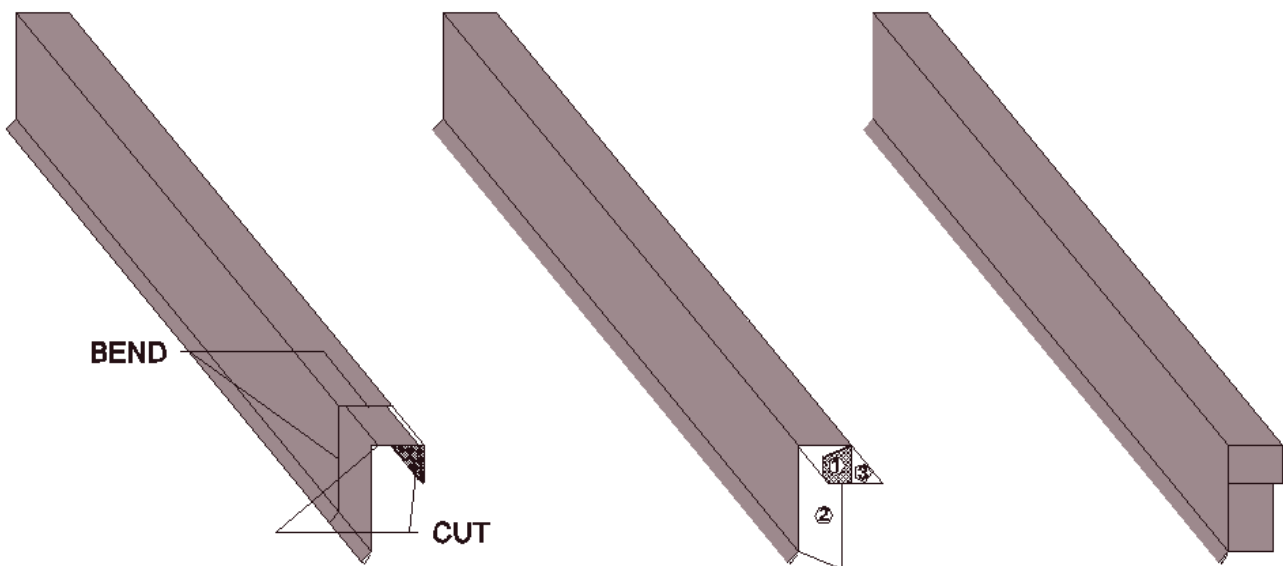

## FOLD SEQUENCE

After placing the gable flash over the panel edge, pull the gable flash over the eave end fascia by 2" to 3" to finish fold. See diagram for cuts and bending locations. Always fold the sides in first and fold the top flap down last so water will run off and NOT run in.

# 1 1/2" SSR TRIM DETAILS

## SIDEWALL

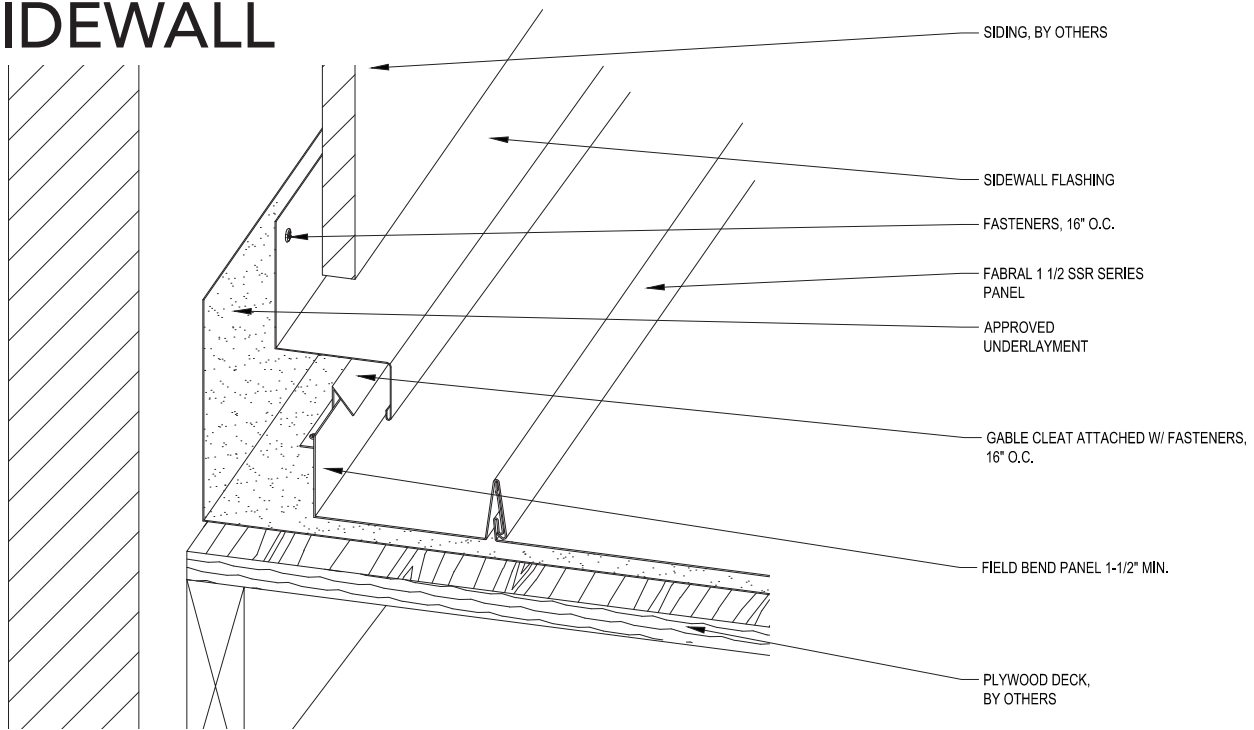

## REGLET SIDEWALL

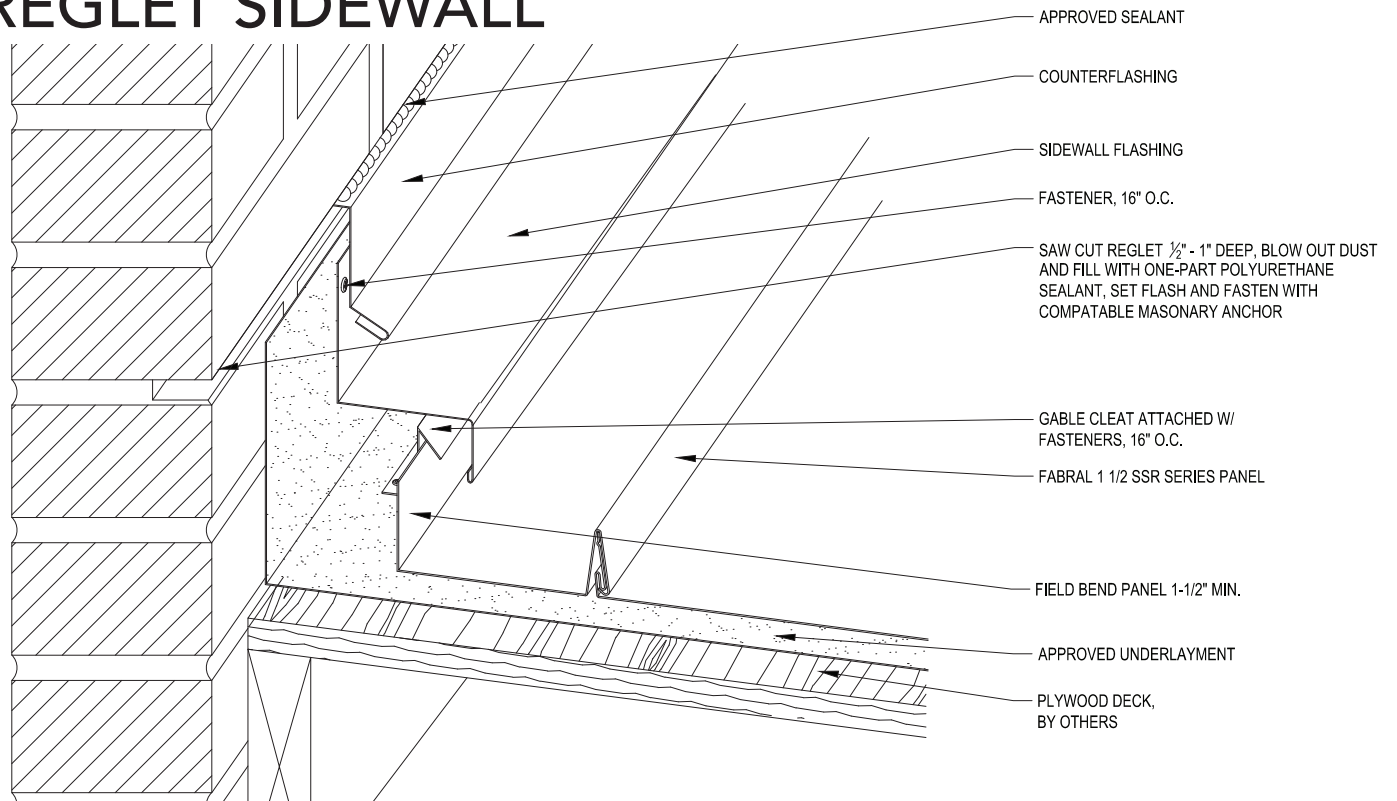

# 1 1/2" SSR TRIM DETAILS

## ENDWALL

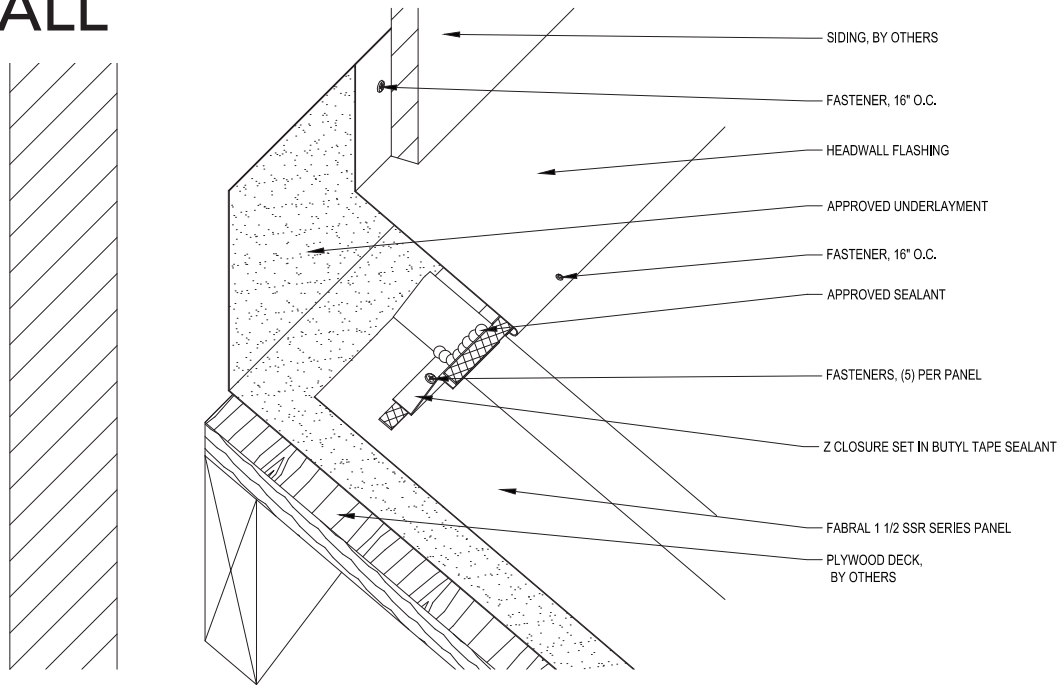

## REGLET ENDWALL

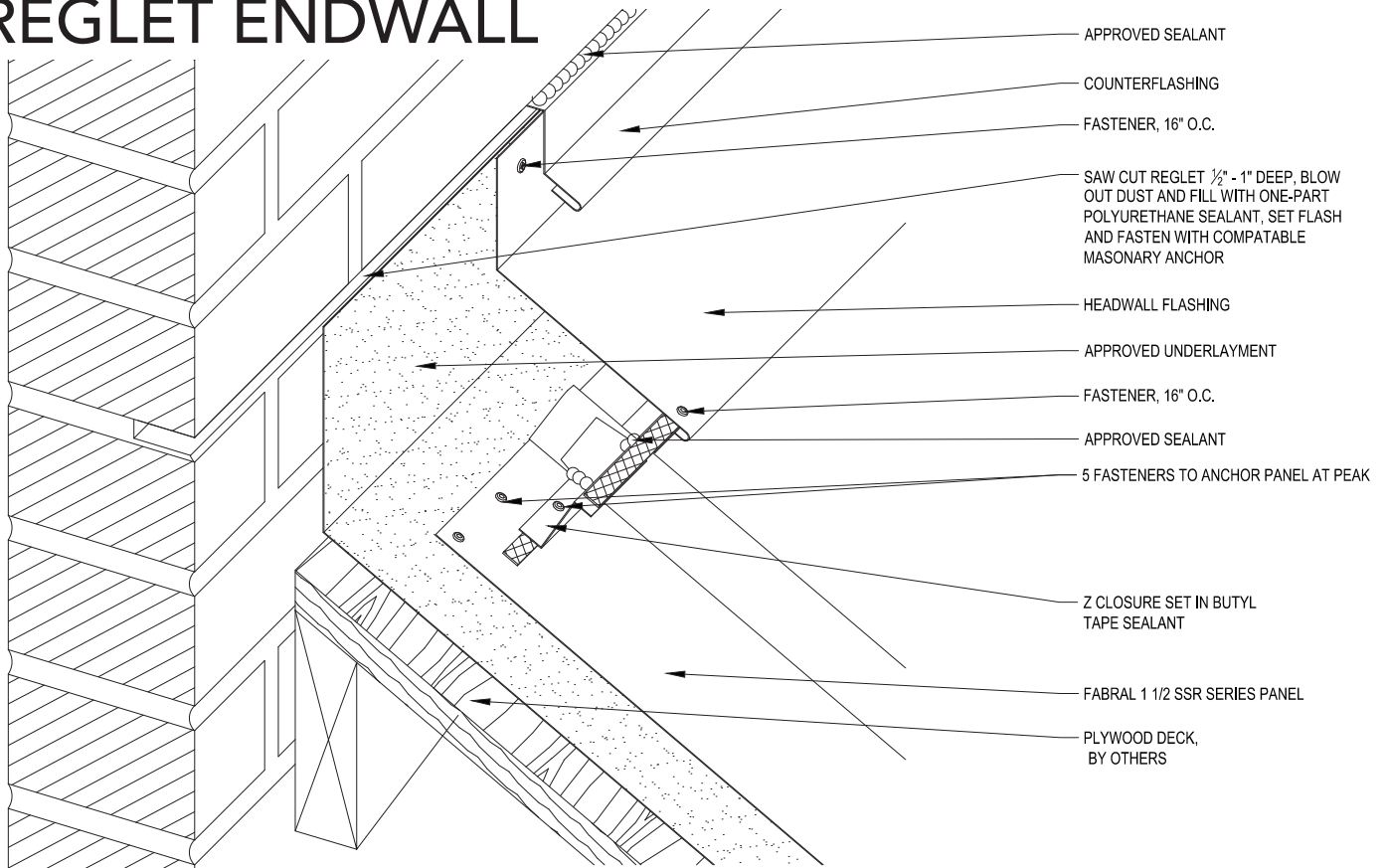



# 1 1/2" SSR TRIM DETAILS

## DORMER

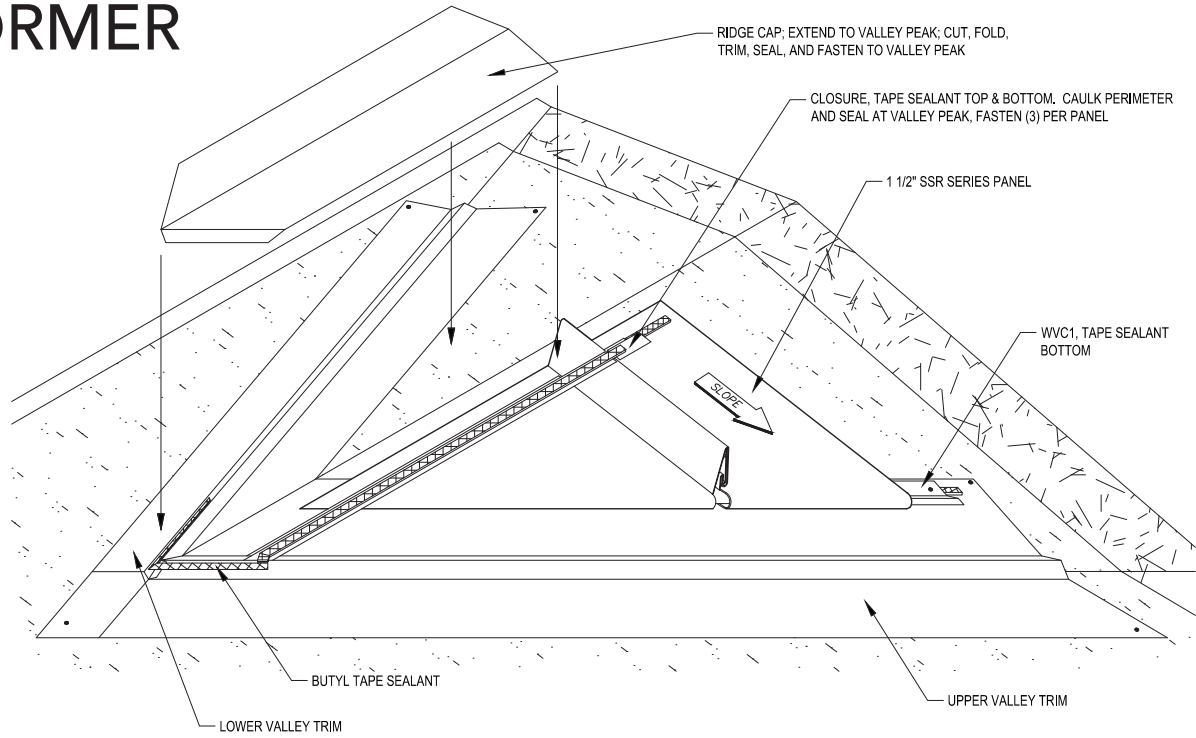

## TRANSITION

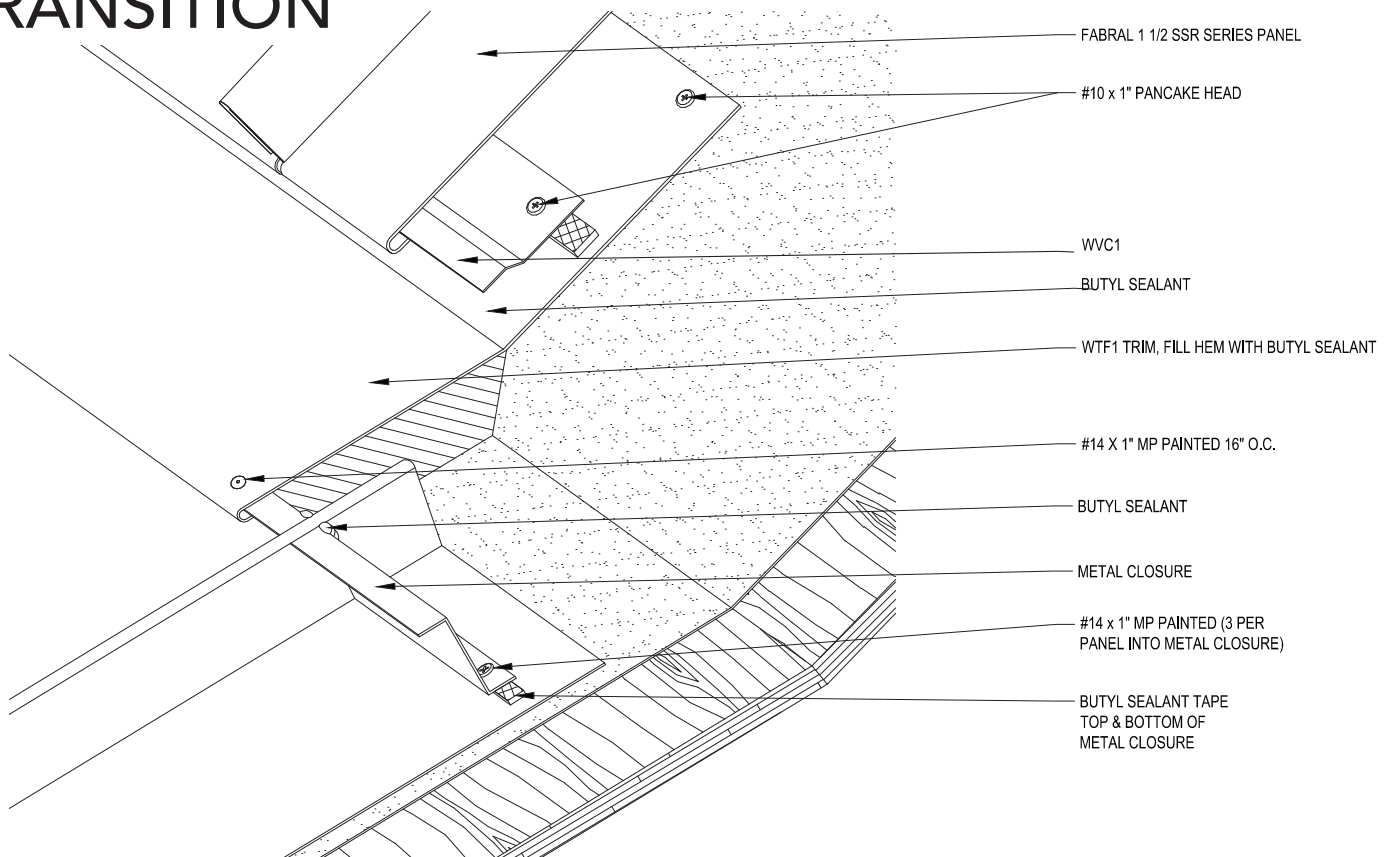

# 1 1/2" SSR TRIM DETAILS

## GAMBREL

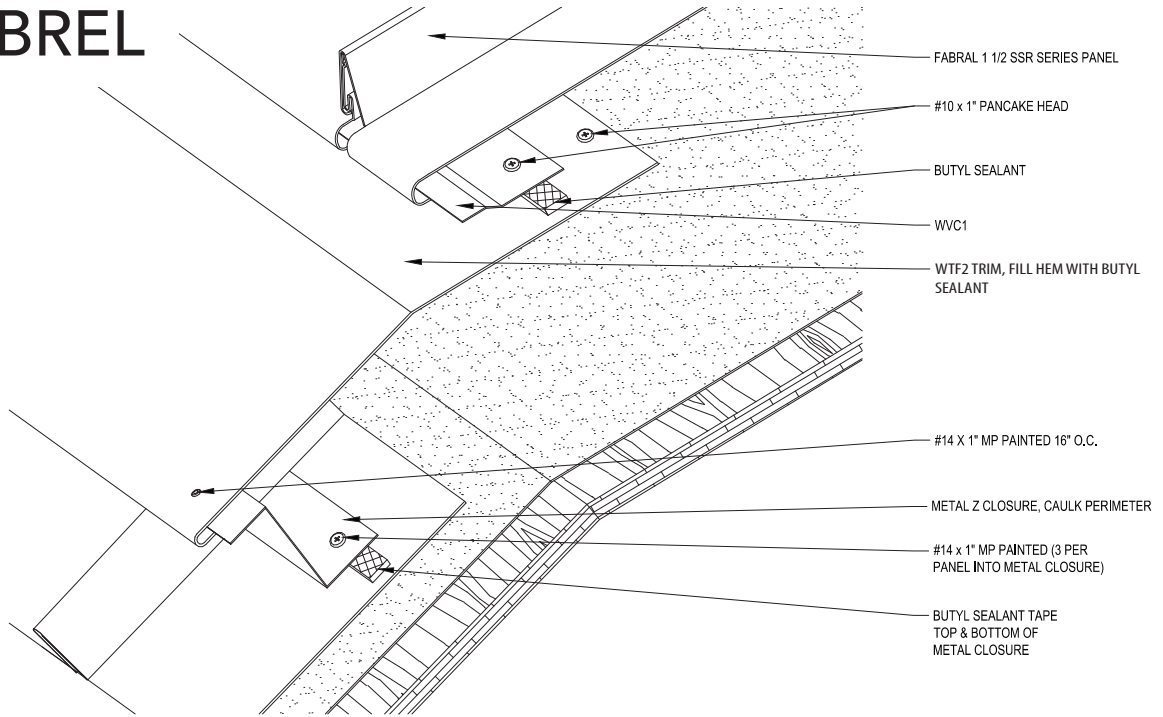

## STEP DOWN DETAIL

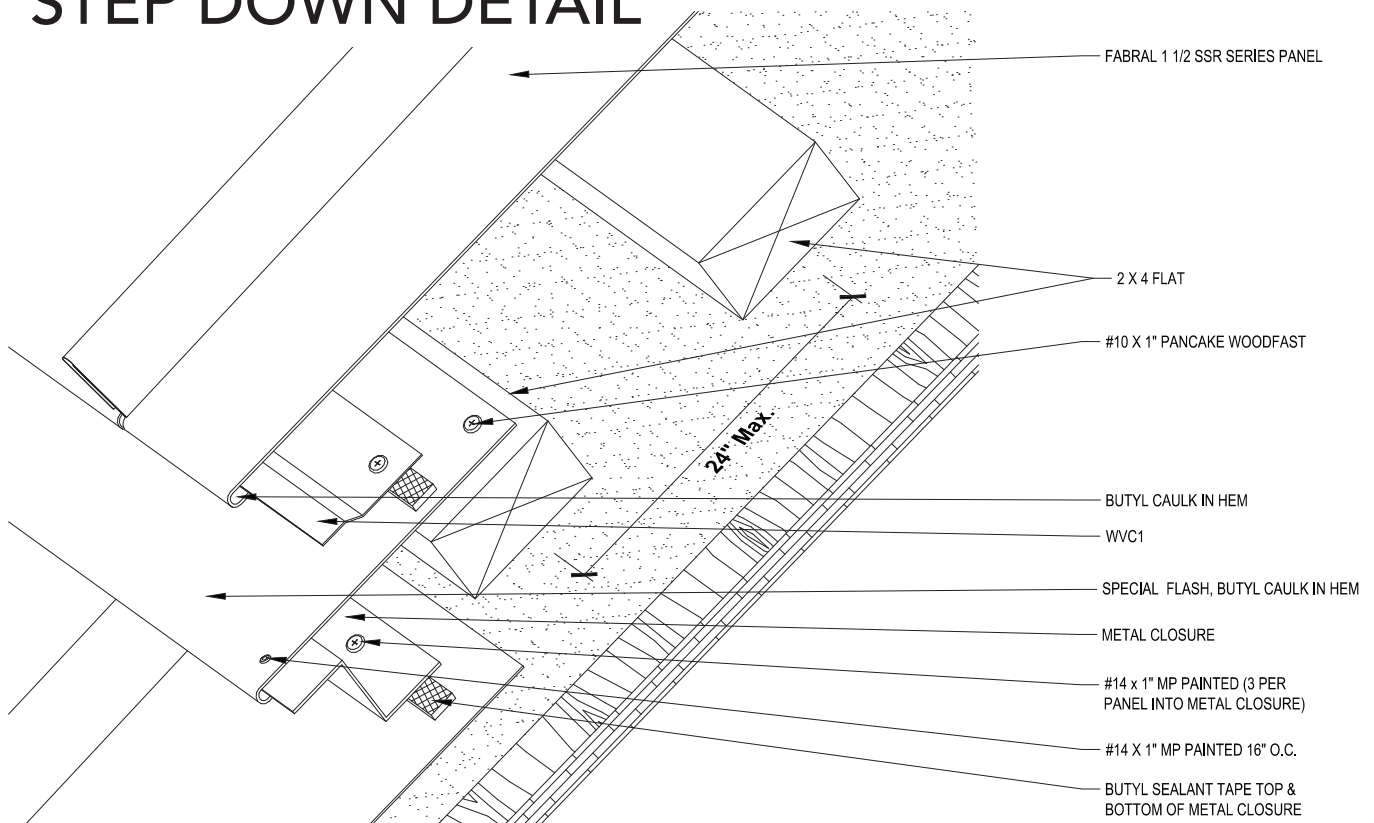

## 1 1/2" SSR TRIM DETAILS

# NONVENTED RIDGE/HIP

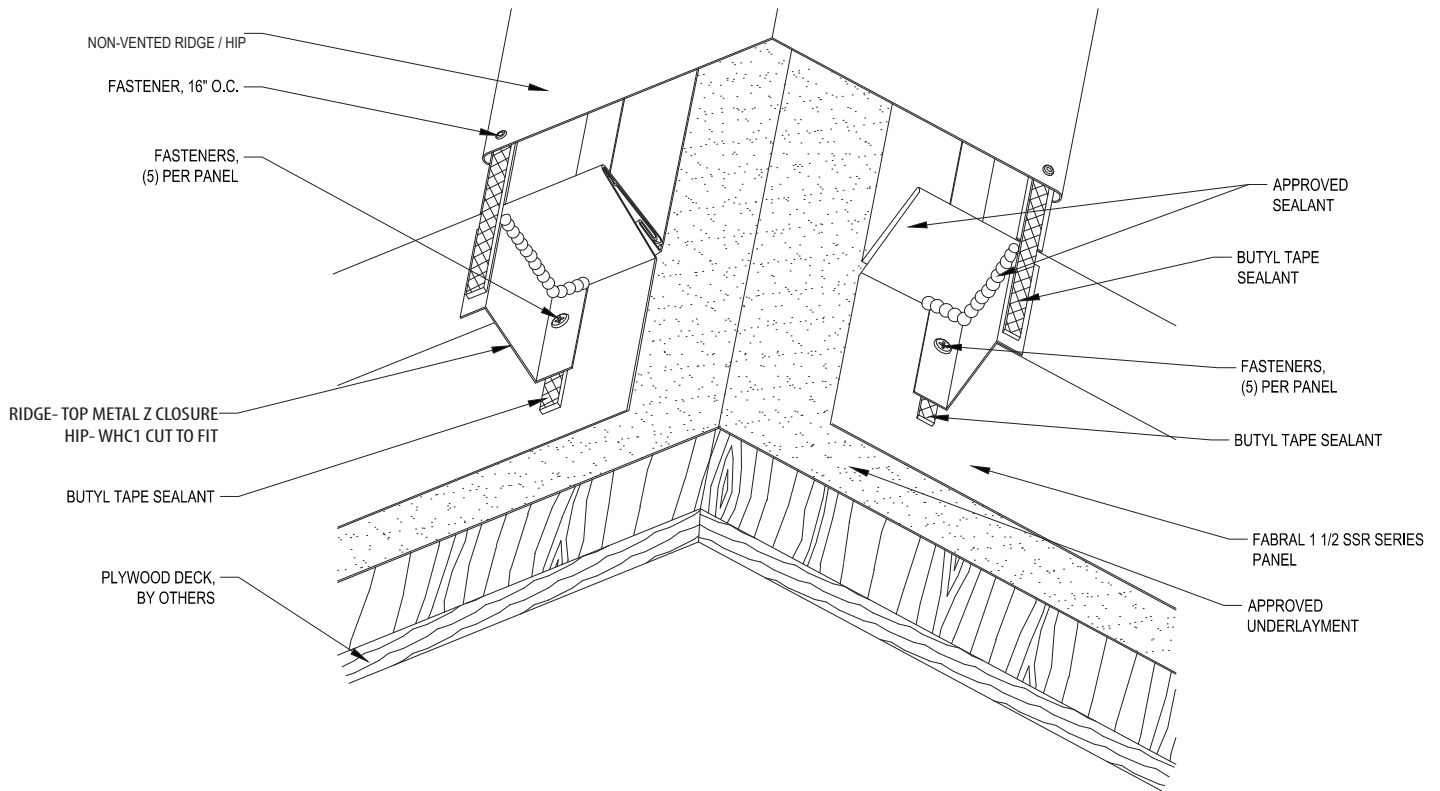

1. Place Butyl Tape caulk in pan of panel.
2. Press Metal Zee Closure firmly into caulk bead in pan of panel.
3. Screw fasten closures into panels and purlin/deck using 5 #14 screws per closure UPSLOPE of caulk bead.
4. Use One-Part Polyurethane sealant up the back side of the vertical web of closures along the panel ribs and over top flange to seal gaps.
5. Hook ridge/hip flash open hem over Metal Zee closure top flange and secure over other side of Zee.
6. Screw both sides every 16" o.c.

### IMPORTANT NOTE FOR RIDGES (VENTED AND NON-VENTED)

The 1 1/2" SSR panel system is allowed to expand and contract from thermal differences, by the panel sliding in the clips. This makes the 1 1/2" SSR a TRUE standing seam system. **The ridge/hip must be fastened securely** through the Top Metal Z Closure/WHC1, through the panel and into the roof decking/purlin with 3 #14x1w Mill Point screws per panel. **If these fasteners are omitted the panels may slide off the roof after installation.** The eave is hemmed to allow the panels to move thermally at the eave without disengaging. If installing snowguards, double the ridge anchor screws.

# VENTED RIDGE

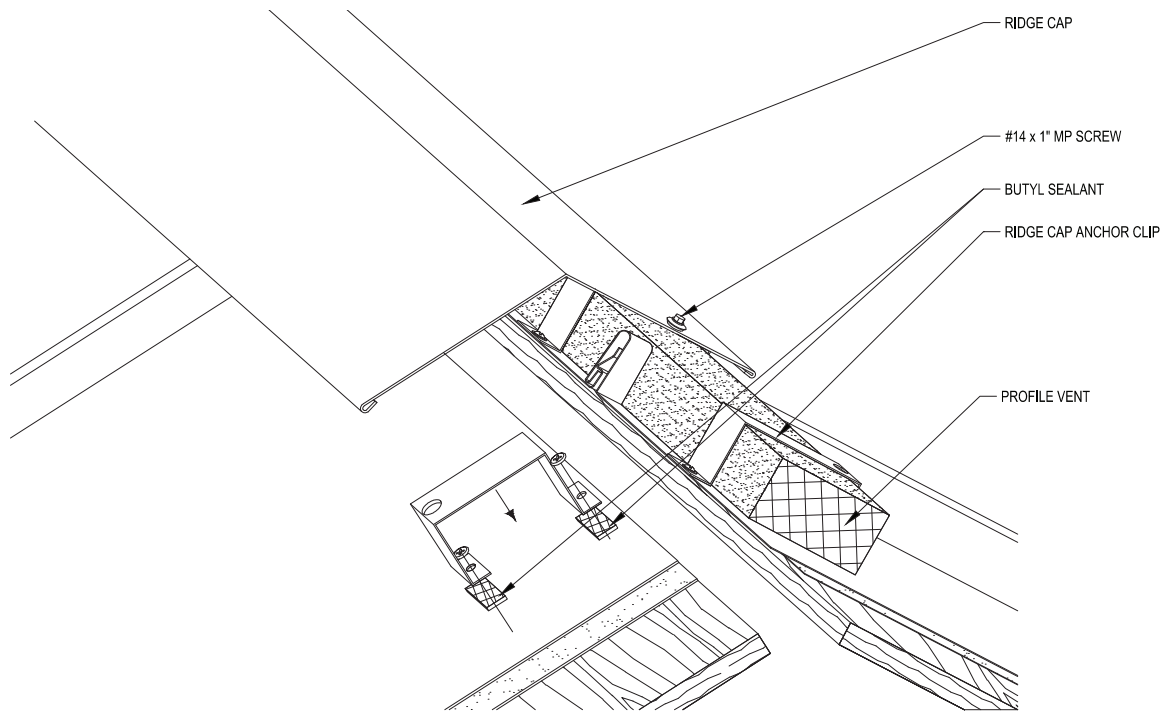

## CoraVent

1. Place Butyl Tape caulk in pan of panel.
2. Press Metal Zee Closure firmly into caulk bead in pan of panel.
3. Screw fasten closures into panels and purlin/deck using 5 #14 screws per closure UPSLOPE of caulk bead.
4. Use One-Part Polyurethane sealant up the back side of the vertical web of closures along the panel ribs and over top flange to seal gaps.
5. Secure CoraVent and the ridge cap on the zee closure using #10 x 1 1/2" Woodfast screws.
6. Screw both sides every 16" o.c.

**NOTE:** Use RR-2 for slopes up to 6:12, Use RR-3 for slopes greater than 6:12

For vented ridge, figure 2 #10x1" woodfast screws for every 1 foot of ridge. CoraVent may need to be cut to fit correctly. For pitches greater than 12/12, contact Fabral.

## Profile Vent

1. Install panels with top edge approximately even with opening in plywood using 2 #14x1" MP fasteners in the panel flat next to each rib. (Do not place a fastener in the center of the panel at this time.)
2. Roll Profile Vent out across the ridge.
3. Place sealant under the bottom leg (leg with access hole) of ridge cap anchor clip.  
**NOTE:** For extra weathertightness add a full strip of butyl sealant under the profile vent.
4. Place anchor clip in center of panel flat, so the vertical part of the lower leg is approximately 3 1/2" from the top of the panel. (refer to diagram)
5. Fasten lower leg with 1 #14x1 MP into the panel using the access hole in the clip (repeat for all panels at ridge).
6. Lift the upper leg of the anchor clip and slide the profile vent under the anchor clip.
7. Place sealant under the anchor clip of the upper leg of the anchor clip and fasten the upper leg using the #14x1" MP. Repeat these steps on both sides of the ridge.
8. Fasten ridge cap using one #14x1" MP through the ridge cap and into the anchor clip (refer to detail)

**NOTE:** Use RR-1 for slopes up to 4:12, use RR-4 for slopes greater than 4:12

# 1 1/2" SSR TRIM DETAILS

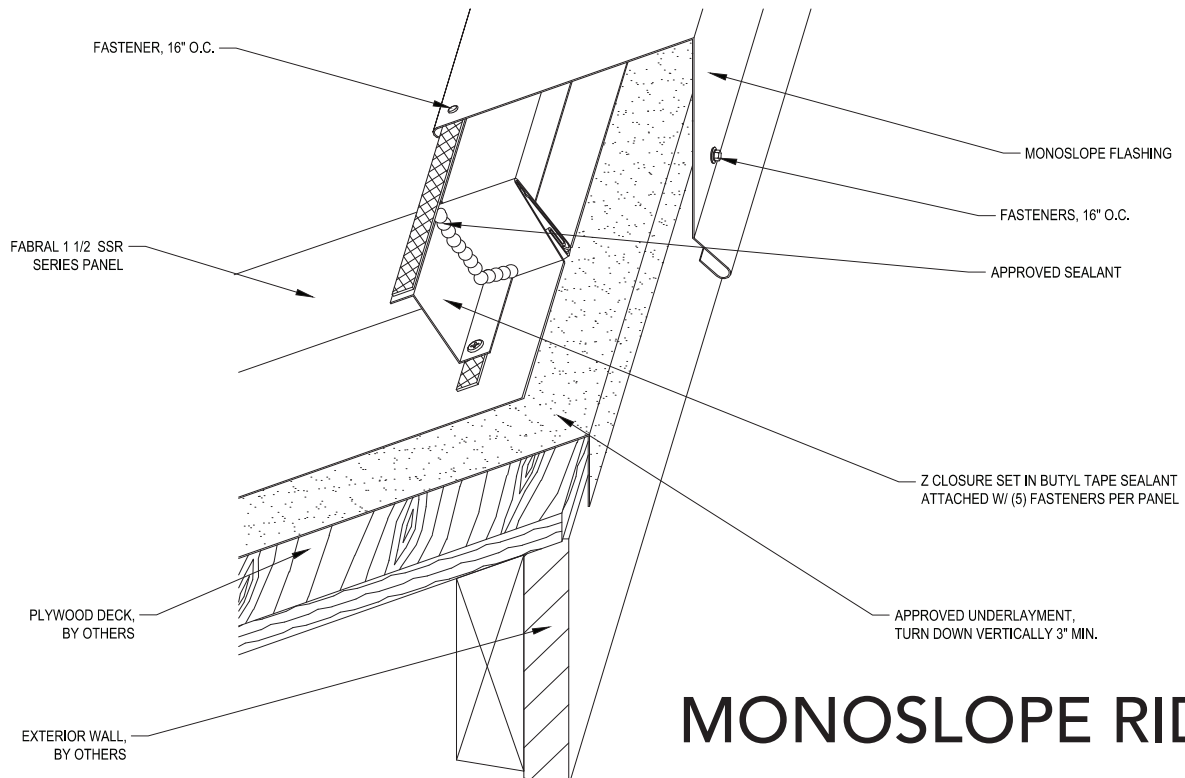

# MONOSLOPE RIDGE WITH SIDING

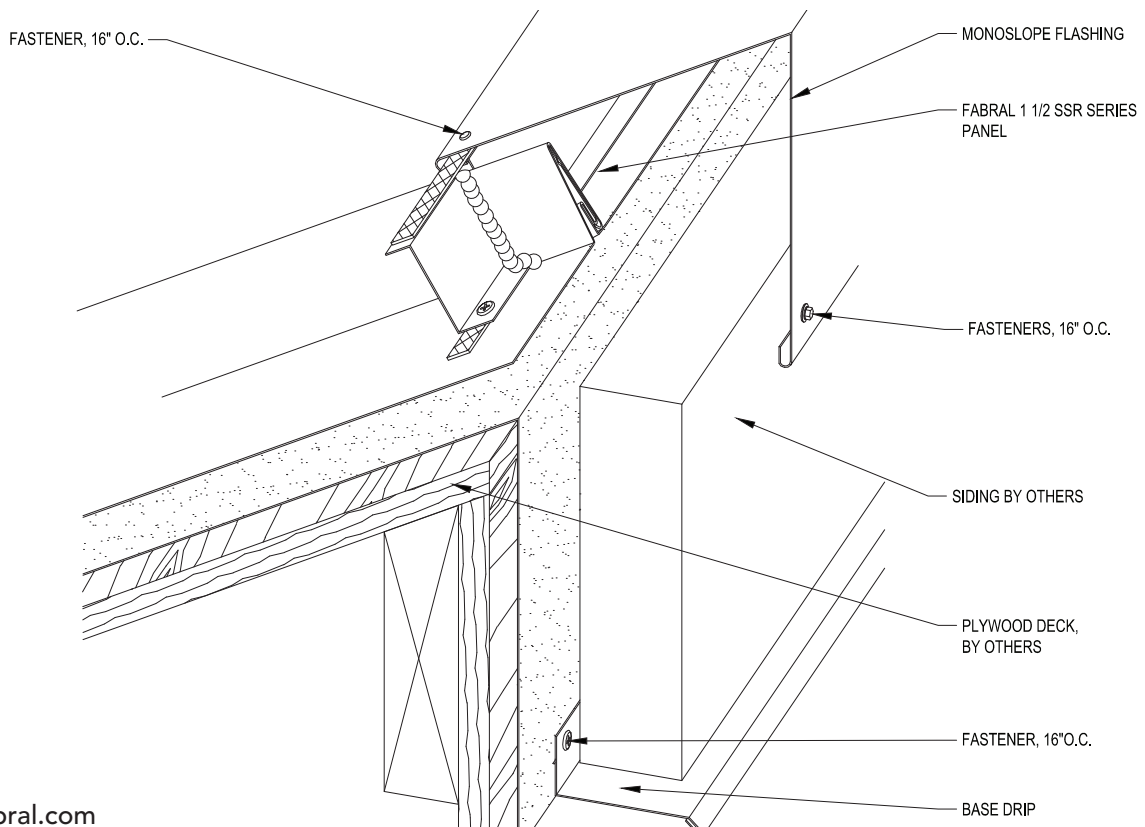

# 1 1/2" SSR TRIM DETAILS

## VALLEY

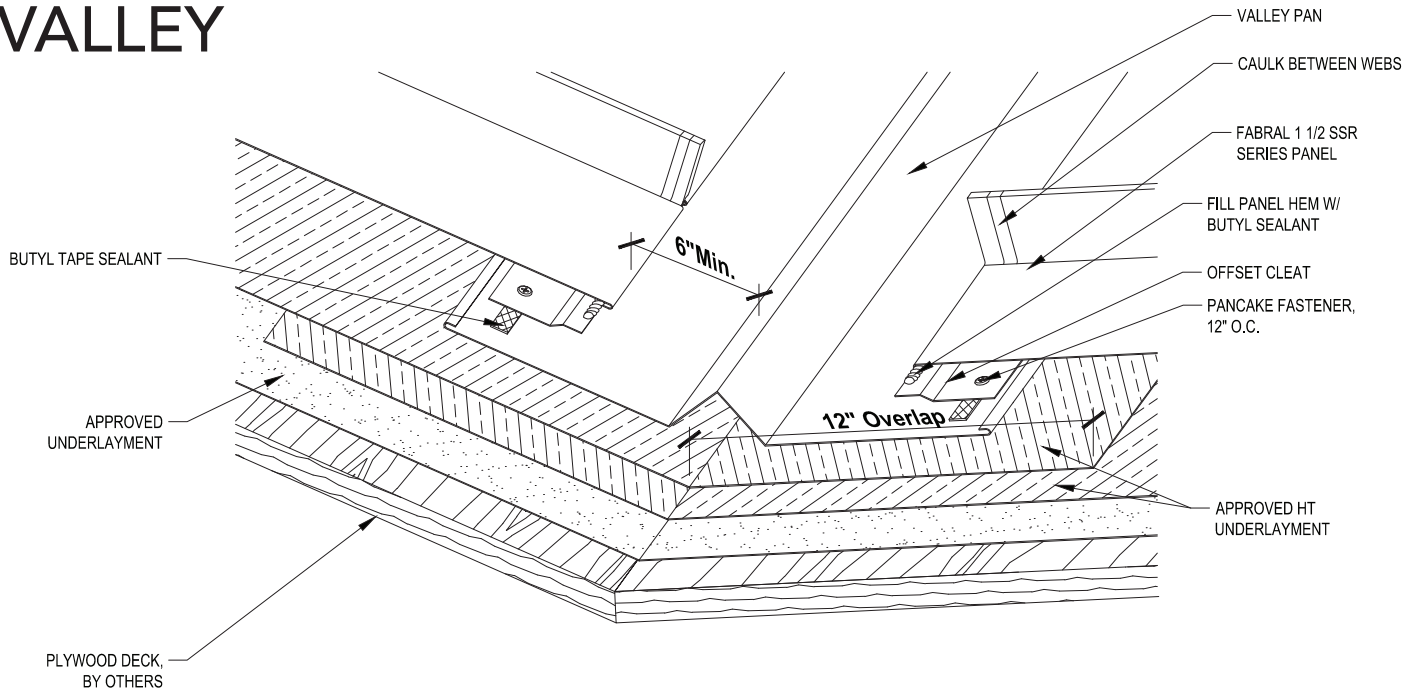

## PIPE BOOT

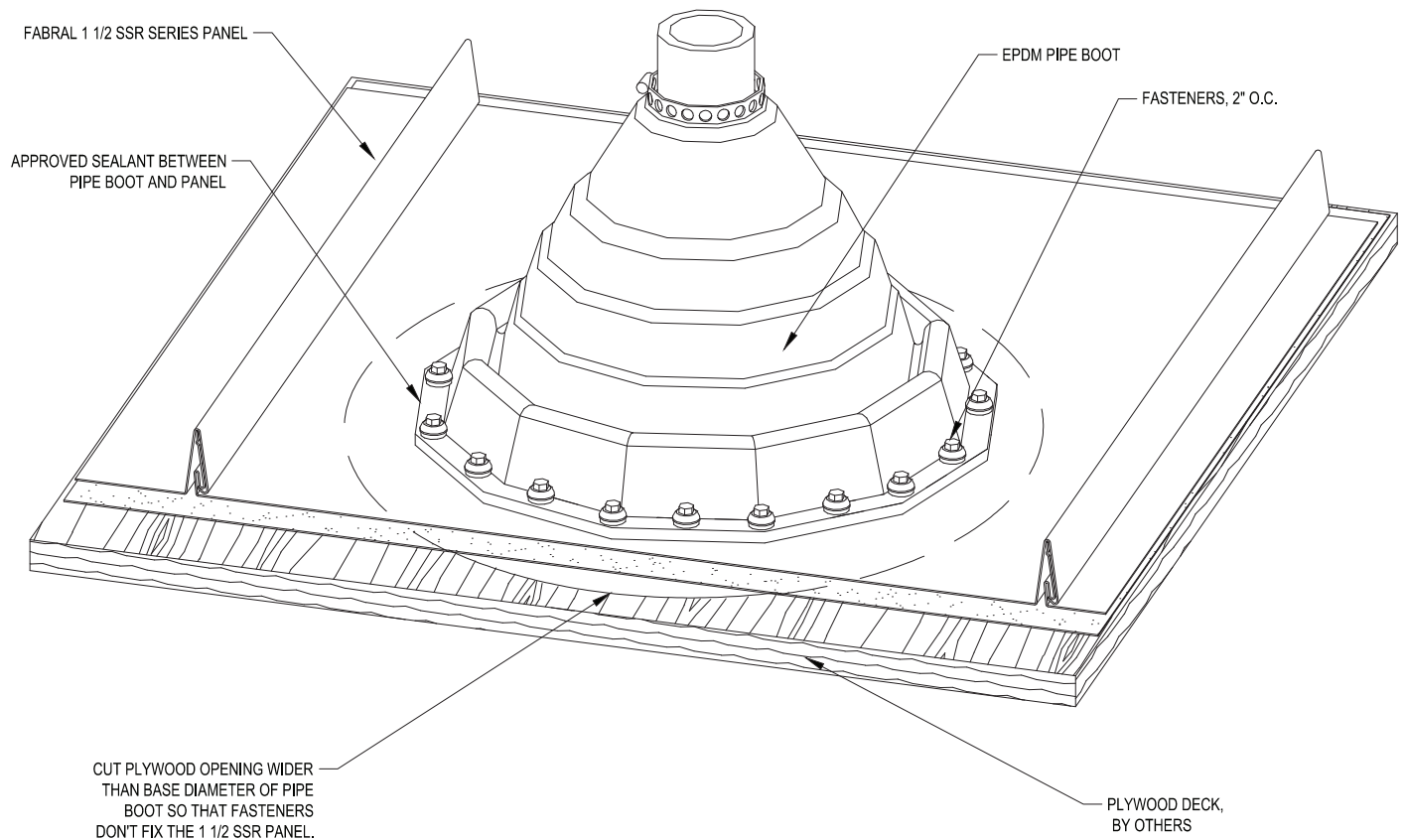

# 1 1/2" SSR TRIM DETAILS

## CURB

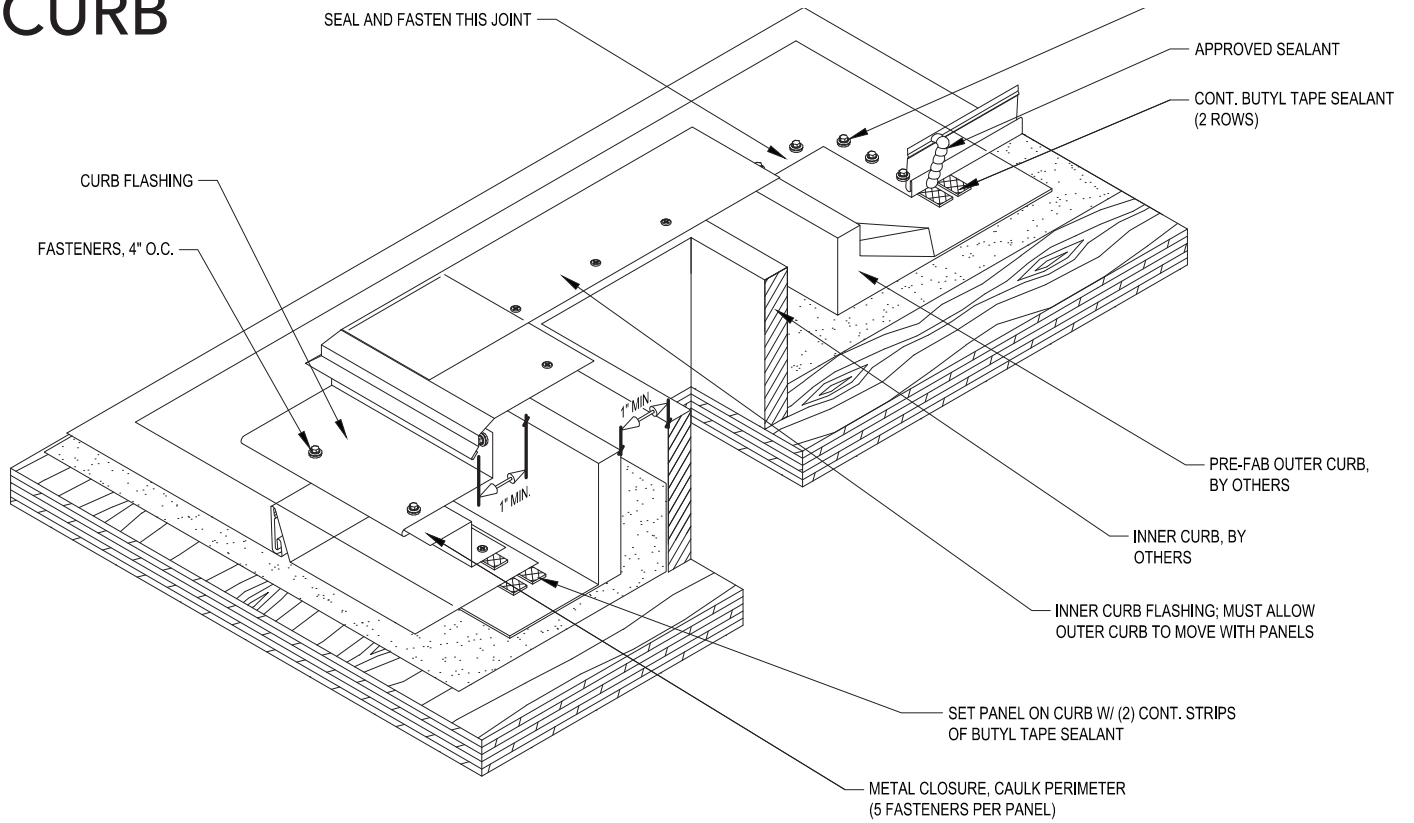

# SKYLIGHTS & CHIMNEY

USE #10X1 PANCAKE HEAD SCREW TO FASTEN VALLEY CLEAT AND VALLEY FLASHING TO DECK. (REFER TO VALLEY DETAIL)

WVC1 VALLEY CLEAT IS NOT FASTENED TO PANEL OR DECKING AT PANEL WHICH RUNS ADJACENT TO SKYLIGHT.

VALLEY FLASHING NOT FASTENED TO PANEL OR DECK AT PANEL WHICH RUNS ADJACENT TO SKYLIGHT

WGC1 GABLE CLEAT FASTENED TO ROOF DECK USING #14X1 MP FASTENERS

TOP METAL Z-CLOSURE  
\* POP-RIVET TO PANEL

POP-RIVETS SHOULD BE INSTALL IN THE PANEL RIB ABOVE Z-CLOSURE LOCATION IN PANELS WHICH BEGIN UNDER THE SKYLIGHT/CHIMNEY

WEW1 ENDWALL FLASHING

POP-RIVET THE TWO PANEL SECTIONS TOGETHER. SEAL POP-RIVETS USING ONE-PART POLYURETHANE SEALANT

TRIM LOWER SECTION OF PANEL RIB TO ALLOW THE RIB TO SNAP OVER THE UNDERLAPPING PANEL

HEM PANEL ALLOWING EDGE TO WRAP AROUND VALLEY CLEAT

WSW1 SIDEWALL FLASHING

TRIM, FOLD AND APPLY ONE-PART POLYURETHANE SEALANT TO AREA WHERE SIDEWALL AND ENDWALL FLASHING JOIN

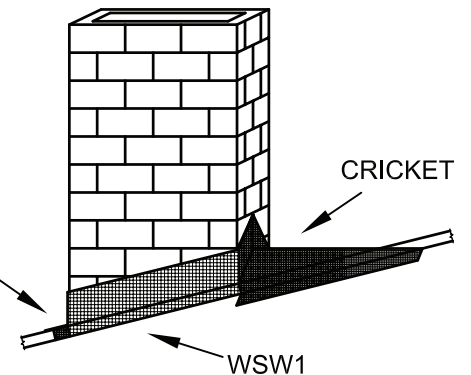

A flexible/formable rubber material, similar to the pipe boots, can be used in place of flashings to outline the entire area around any penetrations. Rubber strips are NOT provided by Fabral.

NOTE: SEE THE FOLLOWING PAGES FOR CROSS SECTIONS

## CRICKET DETAIL

WHC1 "HIP CLOSURE" USE TO CREATE BASE/FRAME OF CRICKET

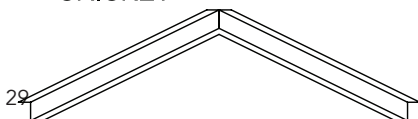

TOP OF CRICKET FIELD FORMED FROM FLAT SHEET

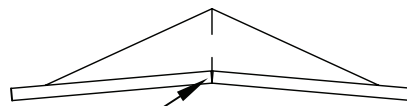

CUT TRIANGULAR CRICKET TOP FOLD UP WIDE END OF TRIANGLE. SLIT CENTER OF FOLD AND BEND SLIGHTLY DOWN THE CENTER.

FASTEN TOP OF CRICKET TO BASE USING #14 MP. CAULK ALL JOINTS AND SEAMS WITH ONE-PART POLYURETHANE SEALANT.

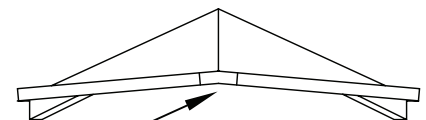

FABRICATE SMALL CAP TO COVER AREA WHICH WAS SLIT



# 1 1/2" SSR TRIM DETAILS

## SKYLIGHT CROSS SECTIONS SECTION A-A

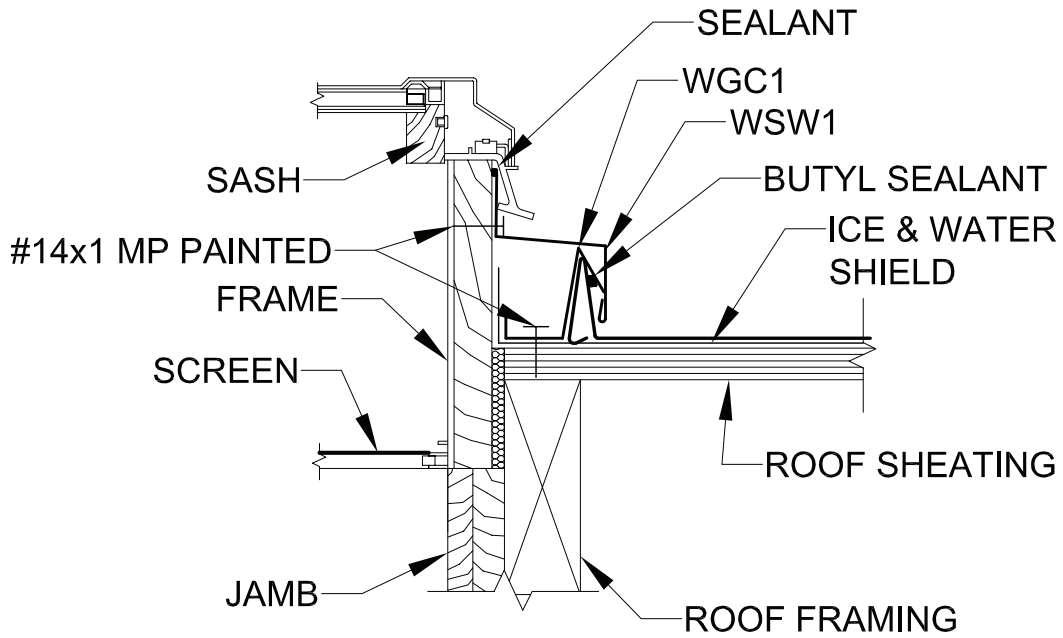

### SECTION A-A

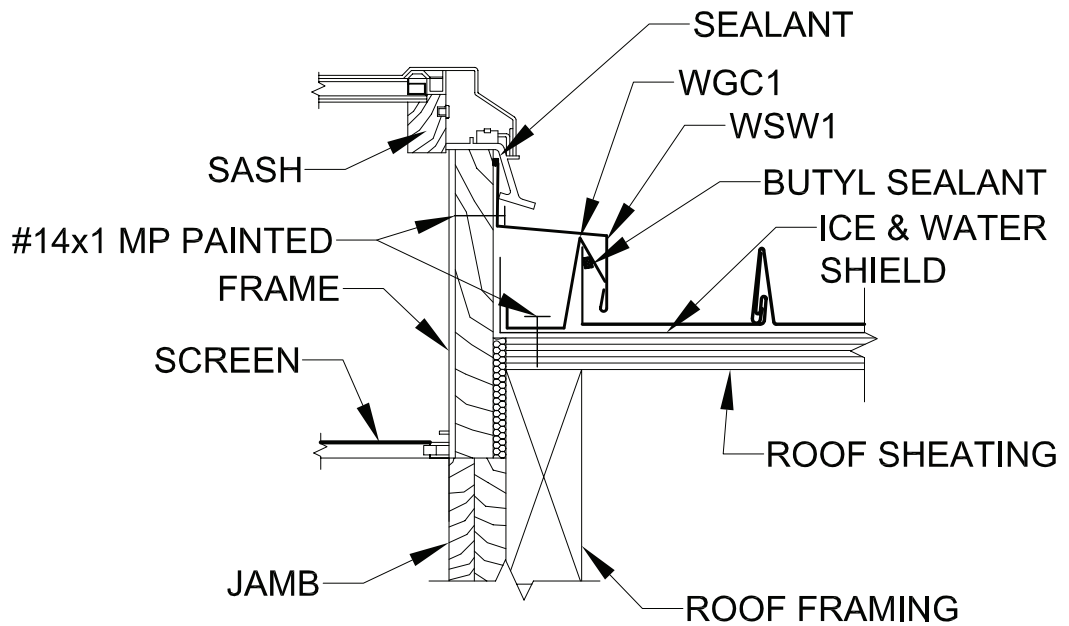

# 1 1/2" SSR TRIM DETAILS

## SECTION B-B

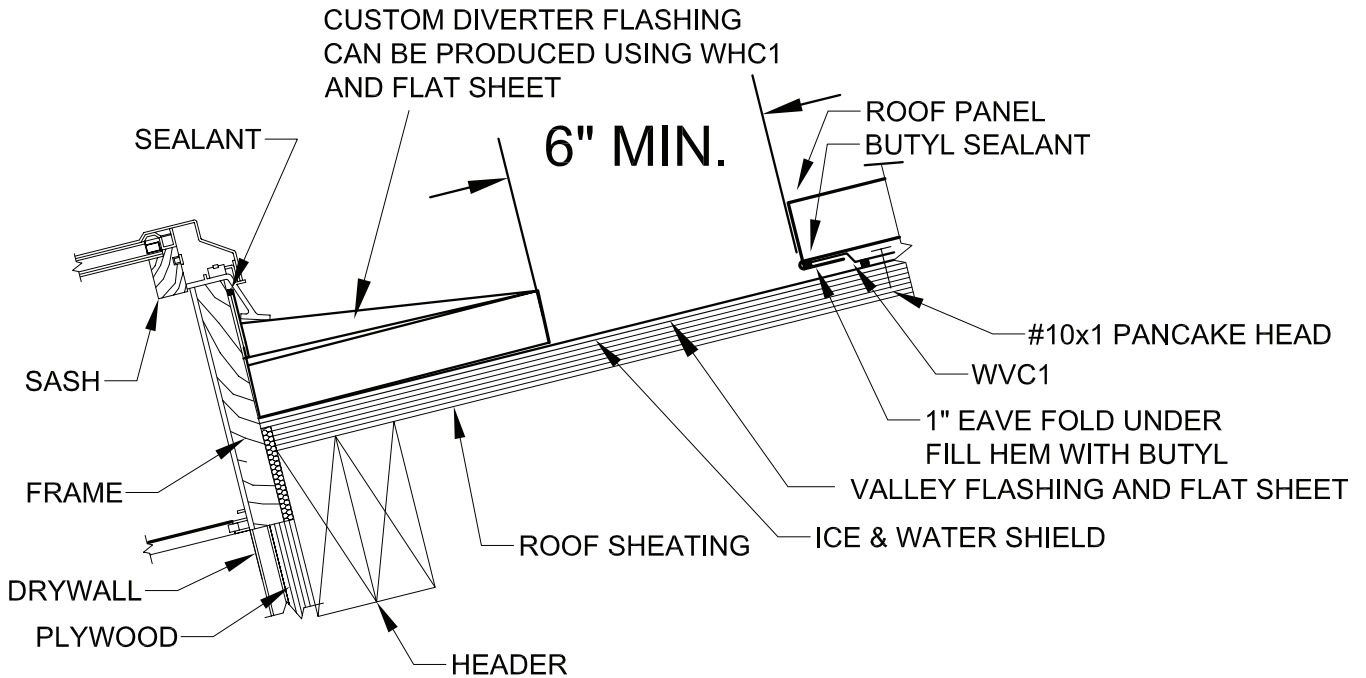

## SECTION C-C

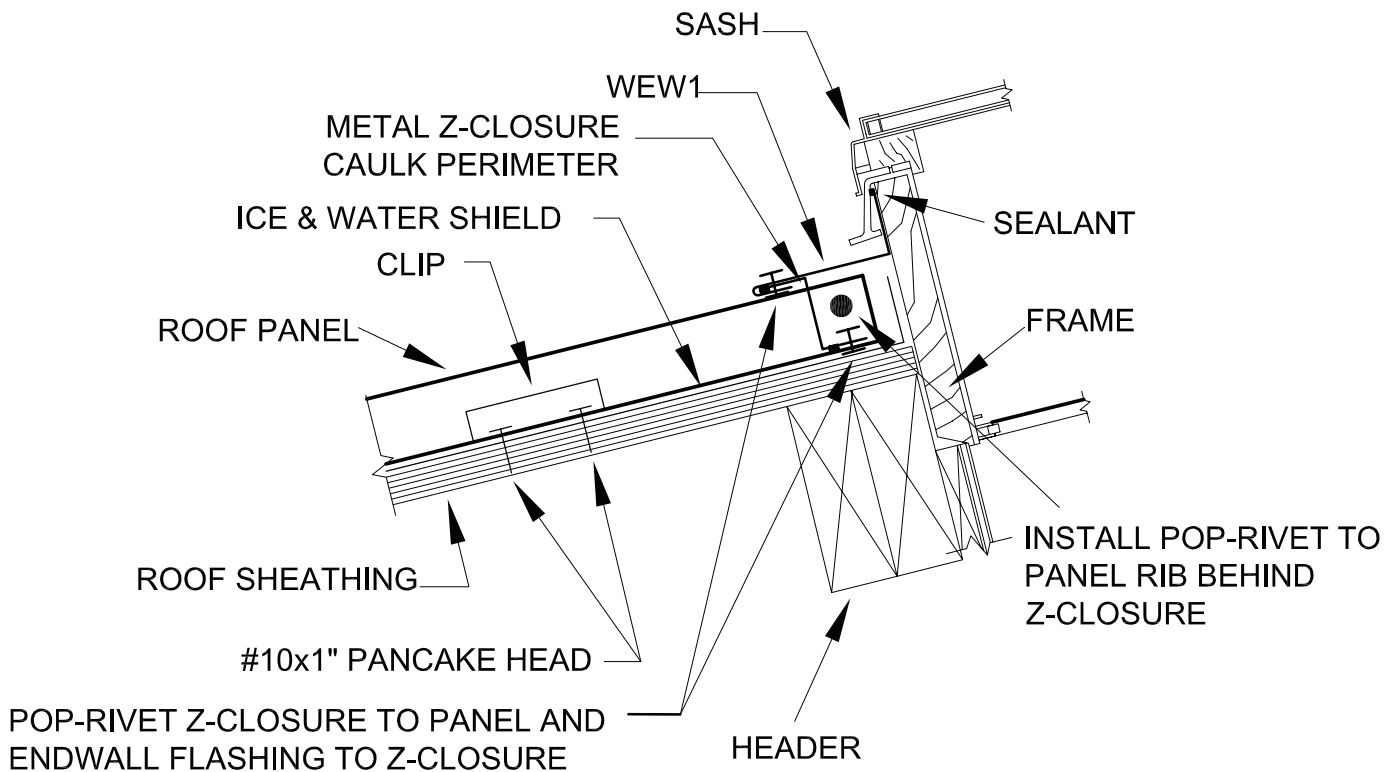

# 1 1/2" SSR TRIM DETAILS

## CHIMNEY CROSS SECTIONS SIDEWALL DETAILS

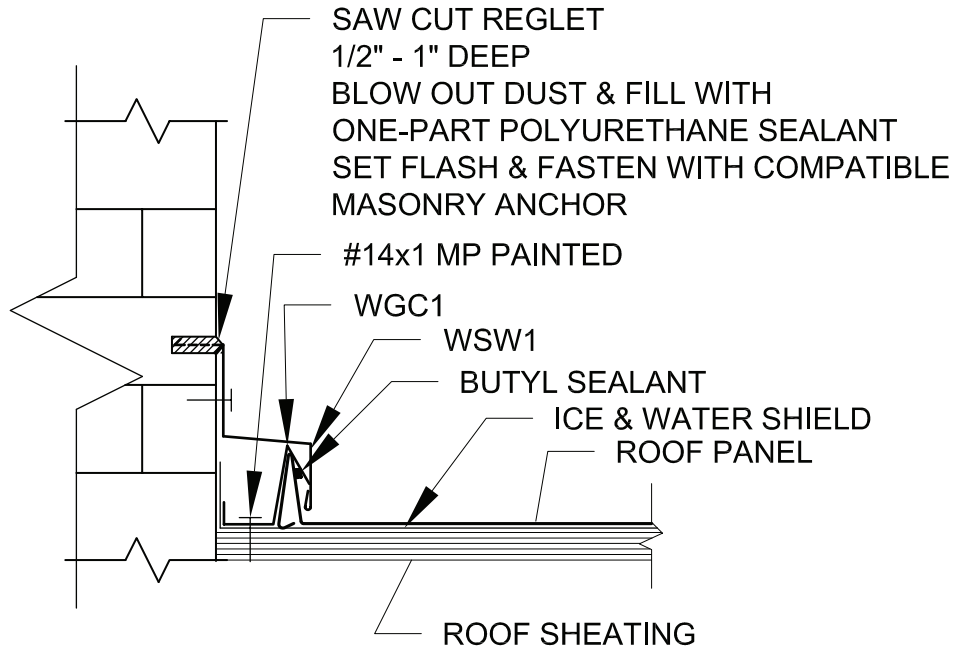

## SIDEWALL DETAILS

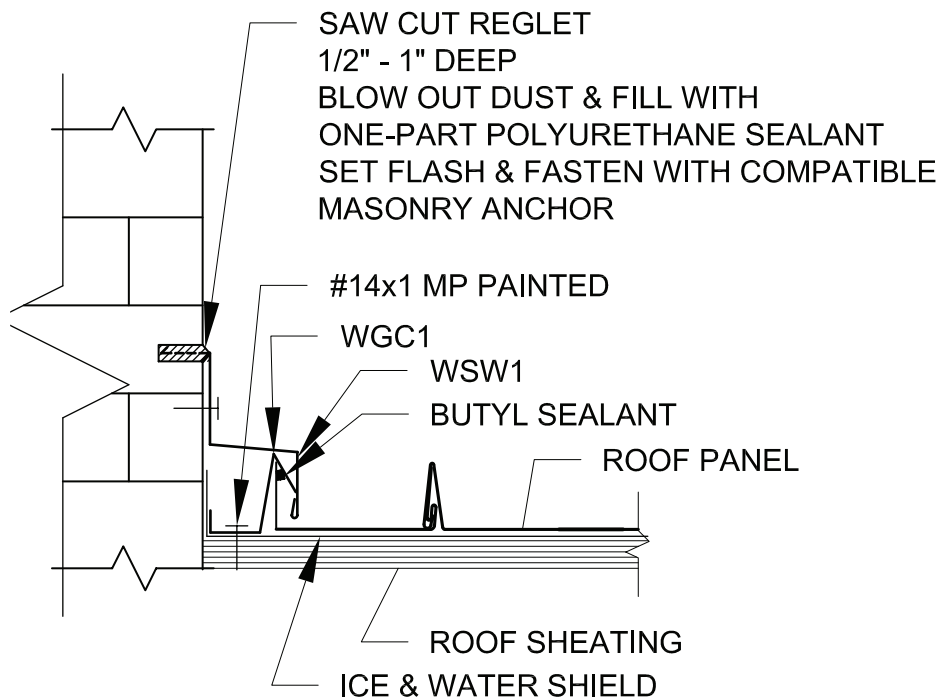

## CRICKET DETAIL

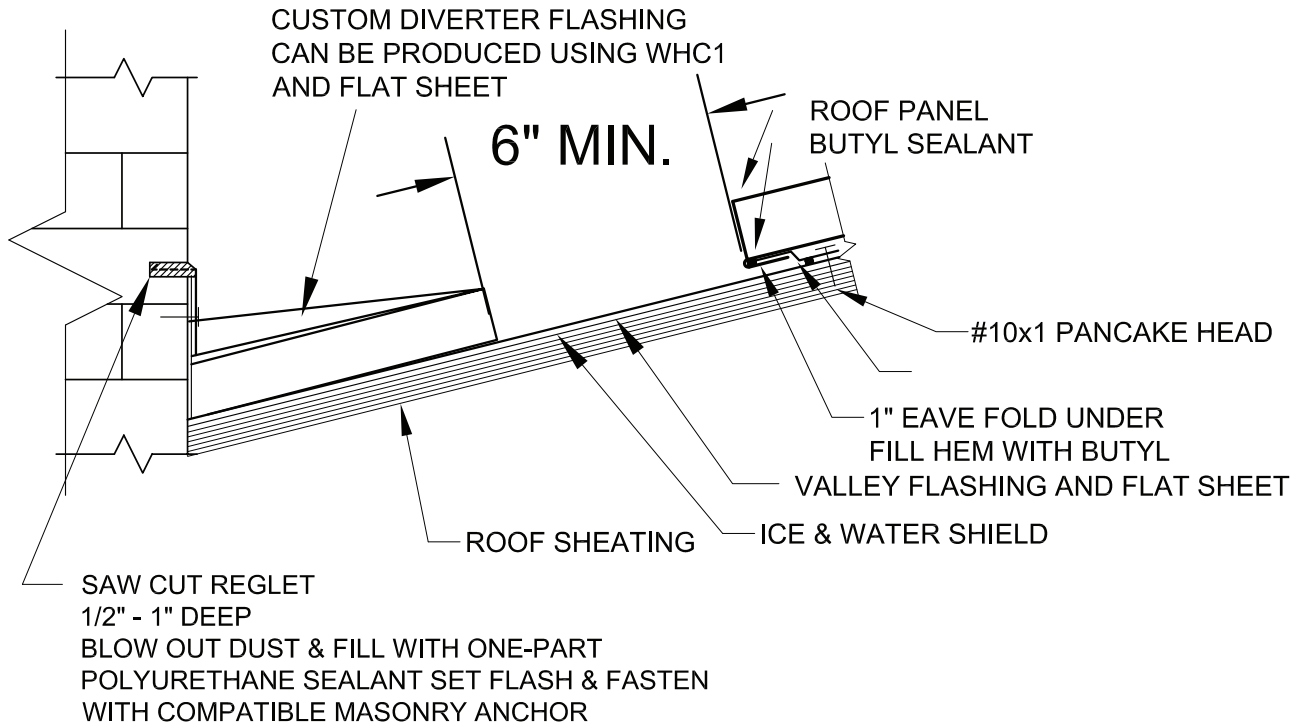

## ENDWALL DETAIL

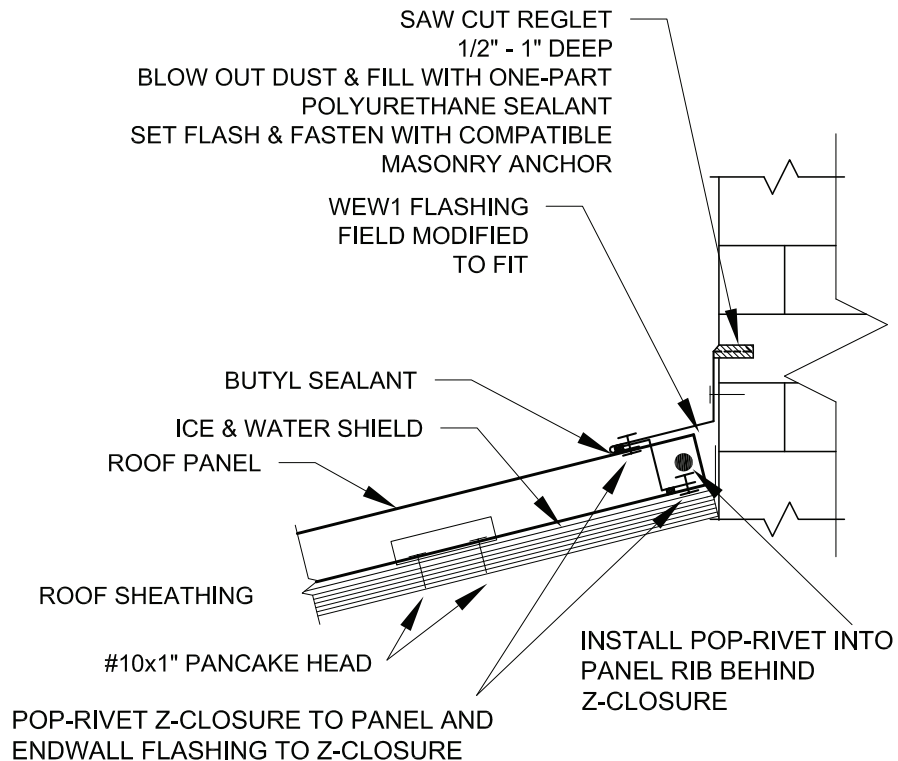

## KEY TERMS

See page 16 for Illustration of Trim Conditions

### CHIMNEY OR SKYLIGHT

See pages 29-31.

### EAVE TRIM

This piece is used at the eave or gutter edge of the building, and must be installed before any panels.

### ENDWALL

This piece is used when the upper end of panel butts into a vertical wall.

### HIP CAP

This piece covers projecting angles formed at the intersection of the two sloping roof planes.

### FASTENERS

**3/4" Stitch Screw:** This fastener is used to attach two pieces of metal to each other.

**#14 x 1" Mill Point:** This fastener is used to fasten into panel near ridge, and can also be used for secure flashings and pipe boots.

**#10 x 1" WoodFast:** This fastener is used to fasten flashing to fascia boards at eave or gable.

**#10 x 1" Pancake Head Screw:** This fastener is used to fasten the clip to the roof deck.

**#43 Pop Rivet:** This fastener is used to attach trim to metal closures.

### GABLE TRIM

This piece is installed on the house between the ridge and the eave, holding down the first panel edge and the last panel edge.

### GAMBREL CONDITION

This trim is used to transition from a low slope on the upper roof to a steep slope on the lower roof.

### MONOSLOPE RIDGE

This piece is used at the top of a single sloped roof.

### RIDGE CAP

This piece is used at the peak of the roof. The ridge can be ventilated by leaving the foam closure out.

### SIDEWALL

This piece is used when the roofing panel is installed parallel to a vertical wall.

### SLOPE TRANSITION

This piece is used where two roofs of different pitch meet; the top section being steeper than the lower section.

### W-VALLEY

Used to flash the valley formed by intersecting roof planes.

## PAINT SYSTEMS & WARRANTY

The Enduracote® paint system takes performance to the next level. Based on cutting edge resin technology, this system offers unbeatable durability and superior long-term performance against the elements.

### The Enduracote® Warranty for Galvalume® Panels

- Lifetime film integrity for walls & roofs
- 30-year against fade & chalk for walls and roofs
- 20 year non-perforation warranty

For profiles: Grandrib 3, 1 1/2" SSR, Climaguard, Mighti-Rib, Horizon S, Horizon 16, Ultra-Loc, Ultra-Rib

Product Warranties are available upon request

**ENDURACOTE**  **PREMIUM DEFENSE**  
Against the Elements

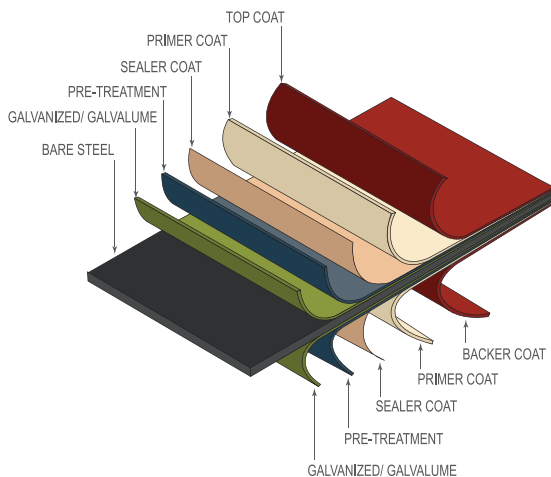

### The ENERGY STAR® Program

The ENERGY STAR Program promotes highly reflective roof systems that reflect solar energy.

These roof systems allow buildings to stay cooler and, in turn, use less electricity for air conditioning; less electricity means a reduction in power generation and a reduction of pollutants discharged at power plants. Fabral has attained ENERGY STAR approval for many of its Enduracote® system colors. Ask for Technical Bulletin #724 titled "ENERGY STAR Approval", for program details and a list of approved Enduracote® colors.

*All Fabral Enduracote Colors are ENERGY STAR® Approved*

*Please contact your Fabral representative for more information about Fabral warranties and paint systems.*

## CONTACT INFORMATION

### Contact by Phone - Nationwide Plant Locations

Cedar City, UT	(800) 432-2725	Marshfield, WI	(800) 528-0878
Ft. Worth, TX	(800) 477-9066	Spokane, WA*	(800) 456-9124 (800) 477-8028
Gridley, IL	(800) 451-3974	St. Joseph, MN	(800) 873-3440
Lancaster, PA	(800) 477-2741	Tifton, GA	(800) 749-8144

### Contact by Email

[info@fabral.com](mailto:info@fabral.com)

[Fabral.com/contact](http://Fabral.com/contact)

### Live Tech Chat

[Fabral.com](http://Fabral.com)

\*Both numbers service Northern California, Oregon, Washington areas

# FABRAL LOCATIONS & SERVICE AREAS

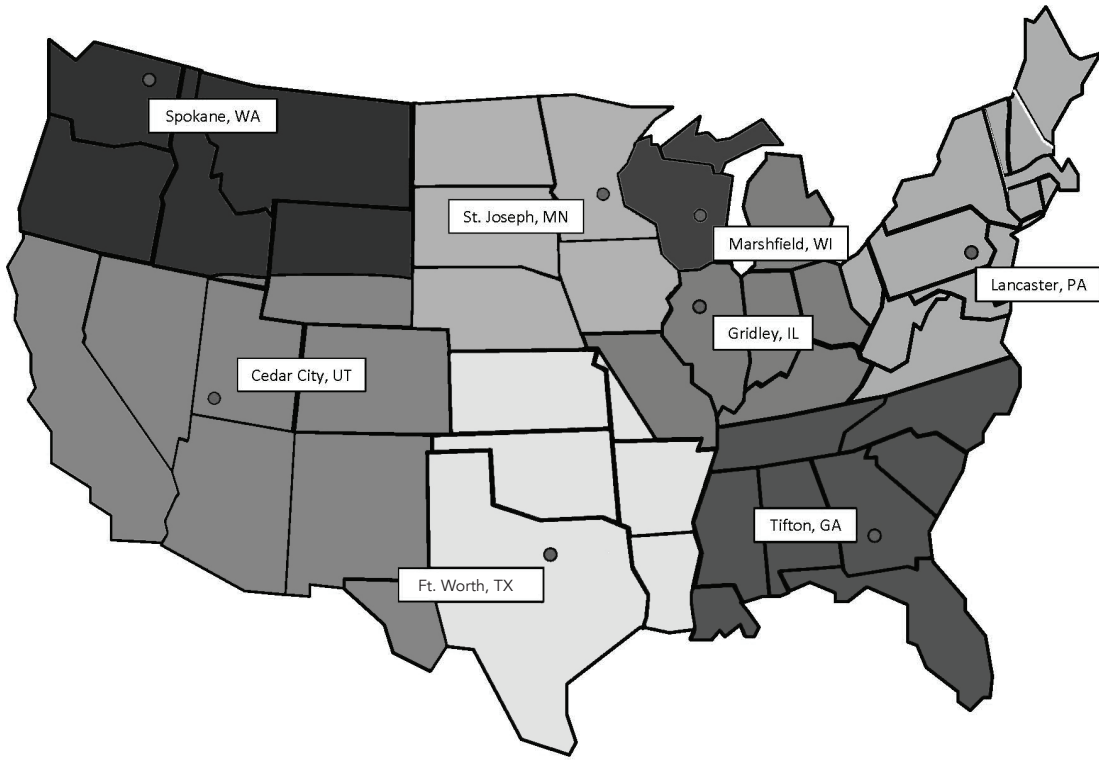

## COLOR AVAILABILITY MATRIX

		Grandrib 3® Plus	Grandrib 3®	Grandrib 3® 26 ga	TrustiRib™ *	Mighti-Rib®	Mighti-Rib® (western region)	5V Crimp 26 ga	Prime Rib®	ProClad®	StrongClad®	2 1/2" Corrugated	1 1/2" SSR	Horizon® S	Climaguard®	Horizon® 16	
<b>Availability</b>																	
Northeast / Mid-Atlantic		■	■	■	■	■						■	■	■			
Southern			■	■	■	■		■				■			■		
Midwest		■	■	■	■	■			■	■	■	■	■	■	■		
Western			■	■	■	■						■				■	
<b>Color</b>																	
Brite White	824 / 724*	●	●	●	●	●	●		●	●	●						
White	899 / 799*	●	●	●	●	●	●			●	●		●			●	
Ivory	883 / 783*	●	●	●	●	●	●		●	●	●				●		
Light Stone	887 / 787*	●	●	●	●	●	●			●	●						
Tan	855 / 755*	●	●	●	●	●	●			●	●						
Cocoa Brown	856 / 756*	●	●	●	●	●	●		●	●	●						
Dark Brown	859	●	●							●	●						
Antique Bronze	854 / 754*	●	●		●	●	●	●		●	●						
Caribbean Blue	881	●	●	●						●	●		●	●	●	●	
Gallery Blue	826	●	●							●	●						
Brick Red	898 / 798*	●	●	●	●	●	●	●		●	●		●	●	●	●	
Brite Red	845	●	●							●	●						
Classic Burgundy	853 / 753*	●	●		●	●	●			●	●		●	●	●	●	
Hickory Moss	870 / 770*	●	●	●		●	●			●	●		●	●	●	●	
Patina Green	893	●	●							●	●						
Evergreen	875 / 775*	●	●	●	●	●	●	●		●	●		●	●	●	●	
Hartford Green	821	●	●							●	●						
Light Gray	889 / 789*	●	●	●	●	●	●		●	●	●			●	●	●	
Charcoal Gray	851 / 751*	●	●	●	●	*	●	●	●	●	●		●	●	●	●	
True Black	882	●	●						●	●	●		●	●	●	●	
Bright Copper Penny	939												●	●	●	●	

\* 700 series color numbers reference the TrustiRib 40-year paint color code  
All panels available unpainted for a mill finish appearance

\* Available from Grapevine, TX facility