

Thin Seam

ARCHITECTURAL ROOFING

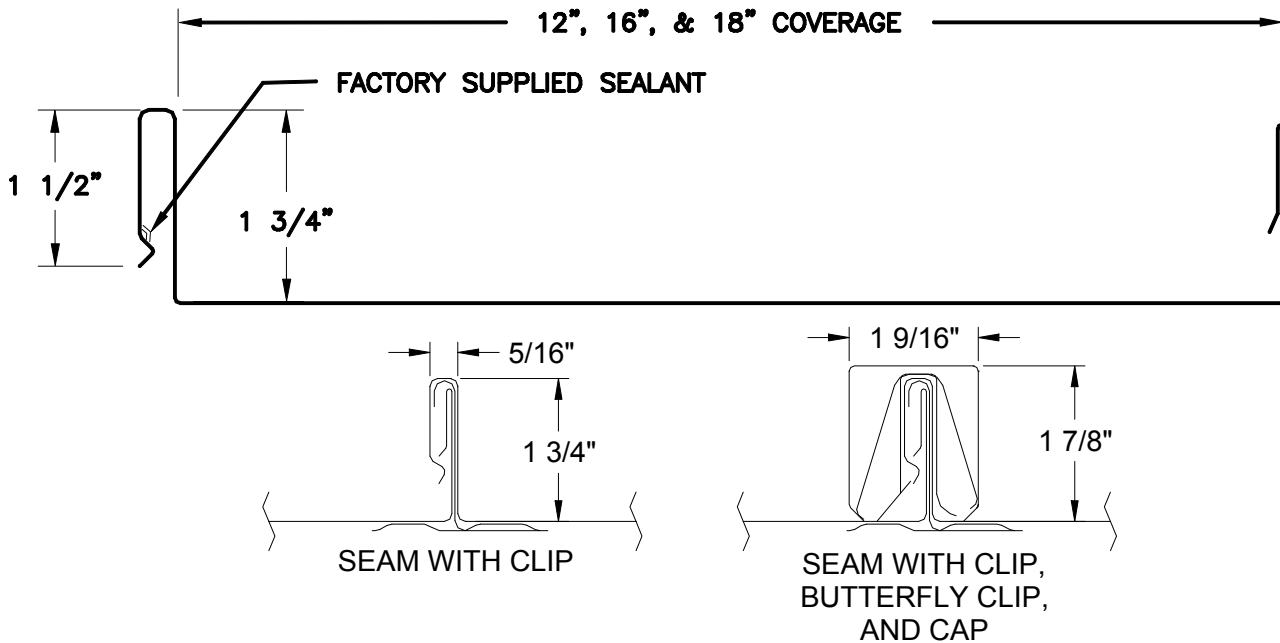

Effective September 2007



GRAVITY LOAD TABLE (psf)

substrate	width	2.5'	3.0'	3.5'	4.0'	4.5'	5.0'
24 ga. steel	12"	78	75	72	69	67	64
24 ga. steel	18"	52	50	48	46	44	41
22 ga. steel	12"	98	95	91	87	84	81
22 ga. steel	18"	65	63	61	58	56	53
.032" alum.	12"	54	52	50	48	42	34
.032" alum	18"	36	35	31	23	19	15

Notes:

1. Allowable loads are based on 1980 edition of AISI specifications.
2. Deflection is limited to L/240 of span.
3. Values are based on three or more equal spans.
4. FY = 50 ksi for steel panels.
5. Uplift values based on attachment to 16 ga. purlins with 2 #10-16 SD ST screws.

DESIGN INFORMATION

The Thin Seam panels can be custom tapered to a minimum width of 1½" and a maximum width of 18". The maximum length of tapered panels is 40'.

The maximum purlin spacing for Thin Seam panels is 4' on-center.

The minimum required roof slope is 1:12.

Minimum radius for field curving is 200 ft.

Maximum panel length is 65'.

Minimum panel length is 4'.

Oil canning is an inherent trait of light gauge metal products, particularly those with wide flat areas. Many of Fabral panels come standard with stiffening ribs, pencil beads, or shadow lines as these help minimize the appearance of oil-canning. However, due to the limitations of commercially available metals, some oil-canning should be anticipated. Oil-canning in any of Fabral's products will not be cause for rejection of material.

TEST REPORT SUMMARIES

AIR INFILTRATION: had 0.009 cfm/ft.2 leakage with 6.24 psf pressure differential per ASTM E 283.

WATER PENETRATION: There was no water penetration under 5 gal./hr. spray at 15 psf pressure differential per ASTM E 331.

UL90 UPLIFT RATING: 18" wide, 24 ga. panels with clips installed over 5/8" plywood deck with clips spaced 3' o.c. with 2, #10-12 x 1" pancake head screws per clip. All butt and side joints in deck to be sealed with one-part urethane caulk and feathered outward from joint (Construction No. 343).

UL90 UPLIFT RATING: 18" wide, 24 ga. panels with clips installed on 16 ga. steel purlins (55 ksi yield strength) spaced 4' o.c. with 2, #10-16 x 1" self-drilling screws with wafer head per clip (Construction No. 359).

UL90 UPLIFT RATING: 18" wide, 24 ga. panels with clips spaced 4' o.c. on 22 ga. steel deck (33 ksi yield strength) with 2, #14 truss head screws with #3 Phillips drive per clip. Bearing plates, 4½" x 6" x 24 ga. need to be installed under each clip. Rigid insulation (1" to 4" thickness) may be installed between the panels and deck (Construction No. 359A).

UL90 UPLIFT RATING: 18" wide, 24 ga. steel panels with clips installed 2' o.c. on ½" plywood deck with two, #10-12 x 1" pancake head screws per clip (Construction No. 417).

ASTM E1592 WIND UPLIFT TEST: 18" wide, 22 gauge steel panels installed with clips at 5' o.c. Two #10-16 x 1" screws per clip into 16 gauge purlins. Load at failure was 67 psf.

ASTM E1592 WIND UPLIFT TEST: 18" wide, 22 gauge steel panels installed with clips at 2' 6" o.c. Two #10-16 x 1" screws per clip into 16 gauge purlins. Load at failure was 80 psf.

Thin Seam

ARCHITECTURAL ROOFING

MATERIAL & WIDTH	WT./SQ. PLAIN	WT./SQ. PAINTED	METAL SPECIFICATION	FINISH
ALUMINUM 0.032" (12") 0.040" (12") 0.032" (16") 0.040" (16") 0.032" (18") 0.040" (18")	67.9 lb. 84.9 lb. 62.2 lb. 77.8 lb. 60.4 lb. 75.5 lb.	69.3 lb. 85.9 lb. 63.5 lb. 78.7 lb. 61.6 lb. 76.4 lb.	3105-H14 or equal (20 ksi yield strength) aluminum alloy conforming to ASTM B 209.	plain: mill finish painted: two-coat 70% Kynar® 500/Hylar® 5000; 0.5 mil two-coat polyester backer
GALVANIZED STEEL 24 ga. (12") 22 ga. (12") 24 ga. (16") 22 ga. (16") 24 ga. (18") 22 ga. (18")	153.0 lb. 186.6 lb. 140.2 lb. 171.1 lb. 136.0 lb. 165.8 lb.	154.5 lb. 188.5 lb. 141.6 lb. 172.8 lb. 137.3 lb. 167.5 lb.	Grade 50 (50 ksi yield strength) structural steel with G90 coating, both conforming to ASTM A 653	plain: regular spangle painted: two-coat 70% Kynar® 500/Hylar® 5000; 0.5 mil two-coat polyester backer
ALUMINUM-ZINC ALLOY COATED STEEL 24 ga. (12") 22 ga. (12") 24 ga. (16") 22 ga. (16") 24 ga. (18") 22 ga. (18")	148.5 lb. 181.2 lb. 136.1 lb. 166.1 lb. 132.0 lb. 161.0 lb.	150.0 lb. 183.0 lb. 137.5 lb. 167.8 lb. 133.3 lb. 162.6 lb.	Grade 50 (50 ksi yield strength) structural steel with AZ50 coating, both conforming to ASTM A 792	plain: regular spangle painted: two-coat 70% Kynar® 500/Hylar® 5000; 0.5 mil two-coat polyester backer

Weight of optional 0.032" aluminum cap is 21.2 lb./100 ft.
 Weight of optional 0.040" aluminum cap is 26.4 lb./100 ft.
 Weight of optional 24 ga. steel cap is 45.8 lb./100 ft.
 Weight of optional 22 ga. steel cap is 56.0 lb./100 ft.



Jackson, GA (800) 884-4484
 Grapevine, TX (800) 477-9066
 Salem, OR (800) 477-8028
 Headquarters - Lancaster, PA (800) 477-2741

Thin Seam SPECIFICATIONS

PART I GENERAL

1.01 SUMMARY

- A. Prefinished, prefabricated, structural standing seam roof system with interlocking seams manufactured in continuous lengths up to 78' and accessories.
- B. Related Sections
 - 1. Metal decking
 - 2. Rough carpentry, plywood, and underlayment
 - 3. Insulation
 - 4. Membrane roofing
 - 5. Flashing and sheet metal
 - 6. Joint sealers: sealants and caulk
 - 7. Structural framing.

1.02 REFERENCES

- A. American Society for Testing and Materials (ASTM)
 - 1. ASTM A 653: Steel Sheet, Zinc-Coated by the Hot Dip Process
 - 2. ASTM A 792: Steel Sheet, Aluminum-Zinc Alloy Coated by the Hot Dip Process.
 - 3. 3. ASTM B 209: Aluminum and Aluminum Alloy Sheet and Plate.
 - 4. ASTM E 283: Air leakage
 - 5. ASTM E 331: Water penetration
- B. Underwriters Laboratory
 - 1. UL Building Materials Directory
- C. Sheet Metal and Air Condition Contractors National Association, Inc. (SMACNA)
 - 1. SMACNA Architectural Sheet Metal Manual, 1993 Edition.
- D. American Iron and Steel Institute (AISI)
 - 1. AISI Cold Formed Steel Design Manual
- E. Metal Construction Association (MCA)
 - 1. Preformed Metal Wall Guidelines
- F. Code references
 - 1. ASCE, Minimum Loads for Buildings and Other Structures
 - 2. BOCA National Building Code
 - 3. UBC Uniform Building Code
 - 4. SBC Standard Building Code

1.03 SYSTEM DESCRIPTION

- A. Performance Requirements: Provide factory formed, prefinished, continuous interlocking, concealed clip, structural standing seam metal roof system, that has been pretested and certified by manufacturer to comply with specified requirements under installed conditions.
 - 1. Provide UL90 rated roofing system that has been tested in accordance with UL 580 test procedure.
 - 2. Resistance to air leakage: 0.009 cfm/ft. of joint leakage when tested in accordance with ASTM E 283 at static pressure differential of 6.24 psf.
 - 3. Resistance to water penetration: No leakage through panel joints when tested in accordance with ASTM E 331 at static pressure differential of 6.24 psf.
- B. Structural Requirements: Engineer panels for structural properties in accordance with latest edition of American Iron and Steel Institute *Cold Formed Steel Design Manual* using "effective width" concept and Aluminum Association's *Aluminum Design Manual*.
- C. Maximum structural spacing is 4' o.c.

1.04 SUBMITTALS

- A. Product Data: submit manufacturer's specifications, standard profile sheet, product data brochure and finish warranty.
- B. Shop Drawings: shop drawings showing roof plan with layout of panels, clips, clip attachment, underlayment and sections of each flashing/trim condition shall be submitted for approval prior to fabrication. Drawings shall contain material type, metal thickness and finish. Drawings shall distinguish between factory and field fabrication.
- C. Samples:
 - 1. Submit sample 12" long x full width panel, showing proposed metal gauge, seam profile and specified finish.
 - 2. Submit manufacturers standard colors for Architect's selection.
- D. Test Reports:
 - 1. Submit the test reports prepared by Underwriters Laboratory indicating wind uplift rating of proposed roof system. The manufacturer must be listed by name in the UL Directory.

- 2. Submit test reports for air leakage per ASTM E 283 and water penetration per ASTM E 331. Actual independent laboratory certified test results must be submitted.
- B. Certification: submit manufacturer's certification that materials and finishes meet specification requirements.

1.05 QUALITY ASSURANCE

- A. Panel manufacturer shall have a minimum of ten (10) years of experience in manufacturing architectural roofing in a permanent stationary indoor facility.
- B. Panel installer shall have a minimum of two (2) years experience in the installation of concealed clip architectural standing seam metal roofing and show evidence of successful completion of at least three (3) projects of similar size, scope, and complexity.
- C. Underwriters Laboratories wind uplift resistance classification: Roof assembly shall be classified as Class 90 as defined by UL580 specification.
- D. Factory fabricated components shall be crated in cartons marked with the manufacturer's name or trademark and a UL 90 label where applicable.
- E. Field dimensions shall be taken prior to fabrication to verify jobsite conditions.

1.06 DELIVERY, STORAGE, and HANDLING

- A. Panels and flashings shall be protected and properly packaged to protect against transportation damage in transit to the jobsite.
- B. Upon delivery, exercise care in unloading, stacking, moving, storing, and erecting panels and flashings to prevent twisting, bending, scratching, or denting.
- C. Store panels and flashings in a safe, dry environment under a waterproof covering to prevent water damage. Allow for adequate ventilation to prevent condensation. Panels and flashings with strippable film shall not be stored in direct sunlight.
- D. Upon installation immediately remove strippable film from panels and flashings. Protect panels and flashings from foot traffic and from all other trades.

1.07 PROJECT CONDITIONS

- A. Field dimensions shall be taken prior to fabrication to verify jobsite conditions.

1.08 WARRANTIES

- A. Panel manufacturer shall provide a twenty (20) year warranty on the paint finish covering chalking, cracking, checking, chipping, blistering, peeling, flaking, and fading.
- B. Applicator shall furnish written warranty for a two (2) year period from date of substantial completion of building covering repairs required to maintain roof and flashings in watertight conditions.

PART II PRODUCT

2.01 PRODUCT DESCRIPTION

- A. Thin Seam structural standing seam roof system as manufactured by Fabral, 3449 Hempland Road, Lancaster, PA 17601, ph.: 800-477-2741; fax: 800-283-4289.
- B. Panels: the Thin Seam panel shall have a 1¼" seam height, a maximum seam width of ⅜", and a seam spacing of 12", 16", or 18" wide.
- C. Roof panels shall use a one-piece roof clip allowing for thermal movement of the panel system.
- D. The standing seam shall have a built in capillary break with the option of a factory applied sealant in the female leg. Concealed one piece roof clip will engage the panel seal allowing for unlimited thermal movement. The standing seam shall snap lock together without the use of or need for an electric seaming device. Roof panels shall be removable for replacement of damaged materials during and after installation is completed.
- E. The panel system shall be as a true standing seam shape requiring no trapezoidal foam closures, plugs, or fillers at eaves.

2.02 PRODUCT SUBSTITUTIONS

- A. Requests to use alternate systems shall be submitted in writing to the project designer at least ten (10) days prior to bid date. Request shall demonstrate proposed substitution meets or exceeds specified performance requirements. Certified statements, samples and descriptive data shall be included in this submittal request.
- B. Manufacturers listed in this section are prequalified manufacturers. Substitution of manufacturer's products for those specified shall not be allowed at anytime during construction.

Thin Seam

SPECIFICATIONS

2.03 MATERIALS AND FINISHES

- A. Panel materials
1. 24 or 22 gauge, Grade 50 (50 ksi yield strength) structural steel with G90 (0.90 oz./ft.²) hot dipped galvanized coating, both conforming to ASTM A 653.
 2. 24 or 22 gauge, Grade 50 (50 ksi yield strength) structural steel with AZ50 (0.50 oz./ft.²) aluminum-zinc alloy coating, both conforming to ASTM A792.
 3. 0.032" or 0.040", 3105-H14 or equal (20 ksi yield strength) aluminum alloy conforming to ASTM B 209.
- B. Texture: panels shall be smooth or with 1" shadowlines.
- C. Finish: paint shall be full strength 70% polyvinylidene fluoride (Kynar/Hylar* fluorocarbon) baked-on coating, factory applied prior to roll forming. The treatment shall be a two-coat system consisting of a single coat of 0.2 mil. primer followed by a finish coat of 0.8 mil. Kynar topcoat with a total dry film thickness of 1.0 mil ± 0.2 mil. The reverse side of the panels shall be treated with a back coat system consisting of a 0.2 mil. primer with a 0.3 mil. topcoat for a total dry film thickness 0.5 mil.

2.04 ACCESSORIES

- A. Concealed roof clips:
1. A 4" long, 18 gauge galvanized (or stainless) steel UL90 roof clip.
 2. A 2" long, 18 gauge galvanized (or stainless) steel standard roof clip.
- B. Flashing and trim
1. All flashing and trim shall be of the same material, gauge, finish, and color as the roof panels and fabricated in accordance with standard SMACNA procedure and details.
 2. Provide transition rib covers where roofing changes pitch.
 3. Fabricate gutters and downspouts in the same gauge, material, finish, and color as the roof panels.
- C. Fasteners
1. Clips to substrate: screws shall be #10 or #12 diameter, low profile pancake head self-tapping type, zinc plated steel.
 2. Flashings to panels: screws shall be zinc plated with a #14 x 7/8" combination steel and neoprene washer, color to match panel.
 3. Pop rivets: #43 stainless steel, color finish to match panel.
- D. Sealants
1. Shall not contain oil, asbestos, or asphalt.
 2. Factory applied sealant shall be applied in the seam and designed for metal to metal concealed joints.
 3. Field applied panel end sealant shall be mastic tape sealant.
 4. Exposed sealant shall be one-part polyurethane joint sealant. Coordinate color with roof panels.
- E. Closures
1. Ridge and hip closures shall be protected and supported by a formed metal closure manufactured from the same material, color, and finish as the panels.
 2. Metal closures shall be factory fabricated and field-cut as needed.
- F. Thermal blocks
1. Thermal blocks shall be:
 - a. Non-treated wood as per manufacturer's recommendation.
 - b. Extruded polystyrene block.
 - c. EPDM membrane.
- G. Vapor Retarder:
1. Retarder with a permeance of 0.05 or less as determined by ASTM E 98.

2.05 RELATED MATERIALS

- A. Refer to other sections listed in Related Sections paragraph for related materials.

2.06 FABRICATION

- A. Roof panels shall be formed in continuous lengths. End laps will not be allowed.
- B. Panels shall be roll formed on a stationary industrial type rolling mill to gradually shape the sheet metal. Portable rollformers, rented or owned by the installer, are not acceptable.
- C. Fabricate flashings from the same material as the roof system.

2.07 SOURCE QUALITY

- A. Source Quality: obtain metal panels and accessories from a single manufacturer.
- B. Fabrication tolerances: follow tolerances in MCA's Preformed Metal Wall Guidelines.
- C. Tests and inspections
- D. Verification of performance

PART III EXECUTION

3.01 MANUFACTURER'S INSTRUCTIONS

- A. Compliance: Comply with manufacturer's product data, including product technical bulletins, product catalog installation instructions, and product cartons for installation.

3.02 EXAMINATION

- A. Installer shall:
1. Inspect roof deck and/or purlins to verify that they comply with shop drawings and are smooth, even, sound, and free of depressions.
 2. Report variations and potential problems in writing to the architect.

3.03 INSTALLATION

- A. Conform to the standard set forth in the SMACNA architectural sheet metal manuals and the approved shop drawings detailed for the project.
- B. Install panels plumb, level, and straight with the seams parallel, conforming to the design as indicated.
- C. Install panel system so it is watertight, without waves, warps, buckles or distortions, and allow for thermal movement considerations.
- D. Abrasive devices shall not be used to cut on or near roof panel system.
- E. Apply sealant tape or caulking as necessary at flashing and panel joints to prevent water penetration.
- F. Remove any strippable film immediately upon exposure to direct sunlight.
- G. Vapor retarder: The joints, perimeter, and all openings shall be sealed per the manufacturer's instructions to provide a continuous vapor retarder.
- H. Underlayment (solid substrate):
1. Provide an underlayment with horizontal overlaps and endlaps staggered between layers.
 2. Provide ice and water shield membrane at all valleys.
 3. Lay parallel to ridge line with 2½" horizontal laps and 6" vertical laps.

3.04 CLEANING

- A. Dispose of excess materials and debris from jobsite.
- B. Remove filings, grease, stains, marks, or excess sealants from roof panel system to prevent staining.
- C. Protect work from damage from other trades until final acceptance.

* Kynar® 500 is a registered trademark of Atofina Chemicals.
Hylar® 5000 is a registered trademark of Ausimont USA, Inc.